Chapter 1

Safety

1	Safety concept	1-3
2	Regulations and guidelines	1-5
3	Terms	1-6
4	Laser classes	1-7
5	Operational safety	1-9
5.1	Intended use	1-9
5.2	Significant change to the machine	1-9
5.3	Authorized personnel	1-10
6	Hazards	1-11
6.1	Mechanical dangers	1-11
	Dangers due to unexpected movements	1-11
	Dangers handling workpieces	1-11

	Dangers when dealing with tools	1-15
	Dangers when transporting the machine	1-16
6.2	Dangers from electricity	1-16
	Dangers due to the open electrical cabinet	1-17
6.3	Thermal dangers	1-17
	Dangers due to fire	1-17
	Fire hazard	1-17
	Extinguishing fire on the machine	1-18
6.4	Noise hazards	1-18
6.5	Hazards due to laser radiation	1-18
6.6	Combination of dangers	1-19
	Hazards due to remote support	1-19
	Dangers when using a bending foil	1-19
	Dangers during maintenance work	1-19
	Dangers when dealing with burst hydraulic system hoses	1-20
7	Measures to be taken by the manufacturer	1-21
7.1	Danger zones and safeguarding	1-21
7.2	Safety-relevant signs on the machine	1-24
7.3	Safety-relevant signs on the machine (USA and Canada)	1-27
8	Organizational measures to be taken by the user	1-29
8.1	Training and instructing operators	1-29
8.2	Due diligence when operating the machine	1-29
8.3	Water protection	1-30
8.4	Spare parts, accessories, software, operating materials	1-31
8.5	Additional equipment	1-32
9	Residual risks	1-33
10	Disassembly and disposal	1-35

1. Safety concept

Safety chapter The "Safety" chapter describes the safety concept of the machine. It specifies the guards and the manufacturer's design measures for safe operation of the machine.

It points out dangers when handling the machine and specifies measures taken by the user to avoid possible dangers.

The "Hazards" section is based on the manufacturer's risk assessment and describes the residual risk. The user must take measures to prevent the hazards. The measures must comply with the national safety and accident prevention regulations of the country in which the machine is operated.

Safety film "Safety First" In addition to the chapter "Safety", the essential cornerstones of the safety concept for the machine are presented in the safety film "Safety First". The film is available in the customer portal MyTRUMPF: www.trumpf.com.

Warning sign and information plates Dangerous points on the machine are marked with warning signs and information plates.

Warnings The operator's manual contains warnings, which warn of dangers and specify measures to avoid these dangers.

Warnings have the following structure:

- The signal word designates the degree of a danger.
- The danger description specifies the danger and possible consequences if attention is not paid to the danger.
- The measures for prevention of the danger are planned.

Example of a warning:

 **DANGER**

Risk of fatal injury due to falling load!

- Observe the safety regulations for handling heavy loads.
 - Never walk under a suspended load.
 - Use certified tackle and means of transportation of sufficient size.
 - Employ qualified personnel to transport the machine.
 - Carry out transport in accordance with the transport regulations.
-

A warning contains signaling words that are explained in the following table:

Signal word	Description
DANGER	If the dangerous situation is not prevented, death or serious injuries will result.
WARNING	If the dangerous situation is not prevented, death or serious injuries could result.
CAUTION	If the dangerous situation is not prevented, light injuries could result.
NOTICE	If the situation is not prevented, damage to property could result.

Signaling words

Tab. 1-1

2. Regulations and guidelines

Area of application outside of the EU

The machine is intended for use outside of the area of application of the EC Machinery Directive.

The machine is delivered without a CE marking and without an EU declaration of conformity.

Laws and guidelines in the USA

The machine meets the requirements of ANSI B11.3.

3. Terms

Term	Description
Machine	A machine (complete machine) according to the definition in the EC Machinery Directive is the entirety of interconnected assemblies and components, of which at least one component is movable. A machine is designed for a specific application.
System	A system is a network of machines and components that work together.
User	The user is the person who is responsible for the operation of the machine or system and has the authority to issue orders to employees.
Laser	Laser (Light Amplification by Stimulated Emission of Radiation) is a term from physics. It describes the physical effect, although in common parlance often the device, with which laser radiation is generated.
Personal safety equipment (PPE)	Equipment intended to be used or worn by persons in order to protect themselves against hazards to their safety and health.

Terms

Tab. 1-2

4. Laser classes

Beam sources, which emit laser radiation are divided into laser classes according to international standard IEC 60825-1 (USA: ANSI Z136.1, ANSI B11.21). The laser class corresponds to the hazard level of the laser light emitted.

All beam sources which the personnel can come into contact with are listed below.

In addition, other beam sources can be installed which emit laser radiation (for example, light barriers, for component and container query). However, personnel are not exposed to this radiation at any time during operation or during setting and maintenance work.

Laser class	Description	Beam source on the machine
1	The accessible laser radiation is not dangerous under normal, foreseeable conditions.	BendGuard optoelectronic safety device (option) Wavelength 658 nm.
1M	The accessible laser radiation lies in the visible spectral range of 302.5 nm to 4000 nm. The accessible laser radiation is not dangerous for the eye as long as the cross section is not reduced using optical instruments (magnifying glasses, lenses, telescopes).	–
2	The accessible laser radiation lies in the visible spectral range (400 nm to 700 nm). There is no danger to the eyes when the exposure time is limited (up to 0.25 s). Additional radiation parts outside the wavelength spectrum of 400-700 nm fulfill the conditions of class 1. The eyes are normally protected against laser radiation by turning away and closing the eyelids. 3R	–
2M	The accessible laser radiation lies in the visible spectral range of 400 nm to 700 nm. There is no danger to the eyes in the case of short exposure time (up to 0.25 s) as long as the laser beam is not observed through optical instruments (magnifying glass, lens, telescope). Additional radiation components outside the wavelength spectrum of 400-700 nm meet the conditions of class 1M. The eyes are normally protected against laser radiation by turning away and closing the eyelids.	–
3R	The accessible laser radiation is in the wavelength spectrum of 302.5 nm to 10 ⁶ nm and is hazardous to the eye. The power/energy is max. 5x the limit value of the permissible class 2 laser radiation in the wavelength range from 400 nm to 700 nm.	–

Laser class	Description	Beam source on the machine
3B	<p>The accessible laser radiation is very dangerous to the eyes and also to the skin.</p> <p>Looking into the laser beam of class 3B lasers directly is dangerous.</p> <p>The accessible laser radiation from class 3B laser products can damage the skin if the maximum permissible exposure values are exceeded.</p>	–
4	<p>The accessible laser radiation is very dangerous to the eyes and dangerous to the skin. Diffused laser radiation can also be dangerous.</p> <p>Safety precautions must be implemented for laser devices of class 4; adequate eye protection is primarily important.</p> <p>Laser systems of class 4 are usually sufficiently powerful to burn the skin, ignite fires and ionize the atmosphere during focussing. Thus, a series of additional safety measures is required.</p>	–

Overview of laser classes

Tab. 1-3

5. Operational safety

The machine can result in the following dangers if it is used inappropriately or for purposes other than those intended, or else if it is not safe to operate:

- Dangers to the safety of the personnel.
- Damage to the machine and other material assets of the user.

5.1 Intended use

Machine The user may use the machine only in the industrial sector. Installation, operating and transport conditions defined by TRUMPF must be adhered to and maintenance work must be carried out in accordance with the Operator's manual. The user must observe the regulations of the country in which the machine is being operated as well as national and regional safety and accident prevention regulations.

The user may bend cold sheets using the machine.

The following is not permitted:

- Any working procedure that impairs the safety.
- Use of tools from other manufacturers without release by TRUMPF.
- Processing of hot, splintering or brittle materials.
- Laying down objects on areas not intended for this purpose.

Disclaimer Any use going beyond this is considered to be unauthorized use. TRUMPF is not liable for any damage, especially personal injury and damage to property as well as production failures resulting from this. The risk is borne solely by the user. The warranty will be voided.

If the operating company modifies or converts the machine, the operating company becomes solely responsible for the safety of the machine and not TRUMPF.

5.2 Significant change to the machine

Significant change The machine has been significantly changed if a new hazard is posed by this change, which results in an increase in an existing risk or to a new risk which cannot be eliminated or reduced with simple guards.

Simple guards in the aforementioned context include guards which are integrated in the safety circuit of the machine via signal exchange or which shut down or shield dangerous machine functions.

The machine can be optionally equipped with signal and safety interfaces ex works, which make it possible for the user or an integrator to add components to the machine, e.g. a robot or fixture or to integrate the machine in a superordinate system.

The user or integrator is responsible for the safety of the altered machine:

- Integration may only be performed by qualified personnel.
- Connection of components to the interfaces must be performed according to the specification set out by TRUMPF.
- Personnel must not be endangered by components integrated in the machine.
- National regulations must be observed.

Evaluation method

If the user or integrator has made a significant change to the machine, they become the manufacturer of the altered machine.

The user or integrator must carry out an evaluation process (e.g. conformity assessment procedure) for the altered machine in accordance with national regulations (e.g. the EC Machinery Directive). He, as the manufacturer, is responsible for the safety of the significantly changed machine.

5.3 Authorized personnel

- Only authorized and trained personnel must be used for setup and maintenance work.
- Trained specialist personnel may do the following:
 - Transporting the machine and its components to the installation site.
 - Carry out work at the hydraulic, pneumatic and electrical modules.
 - Disassemble the machine and its components.

6. Hazards

The "Hazards" section is based on the manufacturer's risk assessment and describes the residual risk. The user must take measures to prevent the hazards.

6.1 Mechanical dangers

Dangers due to unexpected movements

 **WARNING**

The backgauge can move unexpectedly and at high speeds!

Risk of injury!

- Position the workpiece only after the backgauge has moved to the next position.
- Do not reach over the bending line.

2-axis backgauge or 4-axis backgauge with additional backgauge fingers (option):

 **WARNING**

Unexpected movements of the axes.

Risk of injury!

- Position backgauge fingers from the rear side of the machine.

 **NOTICE**

Risk of backgauge and additional backgauge fingers colliding!

- Before moving the backgauge, additional backgauge fingers must be positioned outside the travel range of the backgauge's Z axes.

Dangers handling workpieces

Processing workpieces can be dangerous. These dangers and measures are different for every workpiece.

Sharp-edged workpieces

⚠ CAUTION

Workpieces have sharp edges!

Cutting injuries of the hands.

- Wear protective gloves.

Upper and lower tool

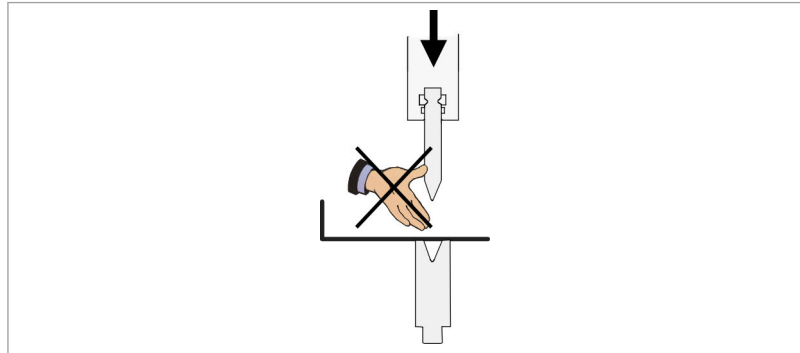

Upper and lower tool

Fig. 25903

⚠ WARNING

Press beam moves downwards!

Body parts can be severed off!

- Do not insert hand between upper and lower tools.

Flange of the workpiece

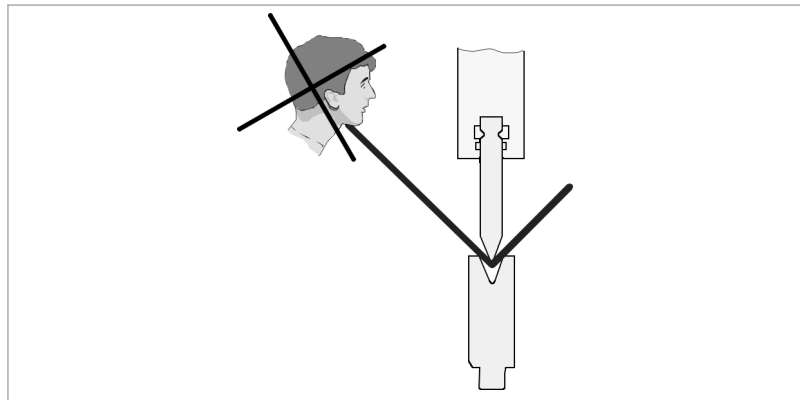

Side swivels far out

Fig. 55869

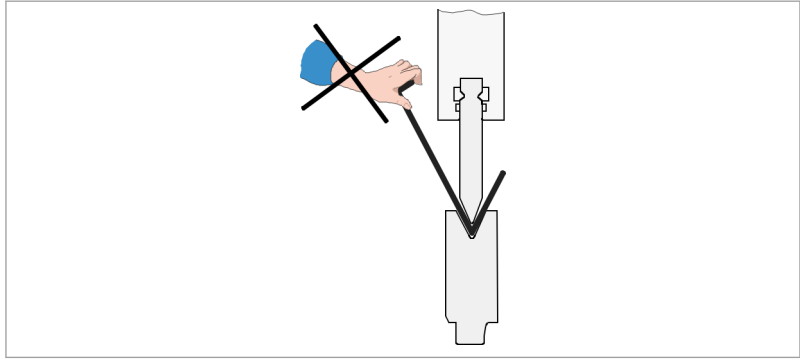

Hand gets caught

Fig. 55828

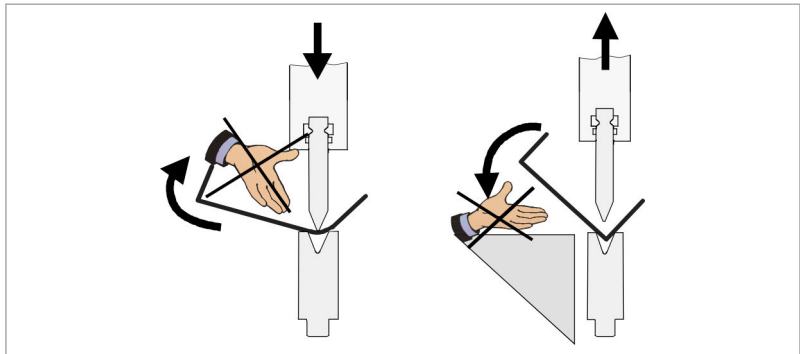

Hold workpiece from the side

Fig. 53449

⚠ WARNING

The flanges of the workpiece swivel upwards or downwards during bending!

Risk of crushing between workpiece and tool clamp as well as between other machine parts in this area.

- Maintain sufficient distance to the workpiece.
- Hold the workpiece in such a way that hands and fingers do not get trapped.
- In the case of support brackets (optional): hold the workpiece at the side after bending.

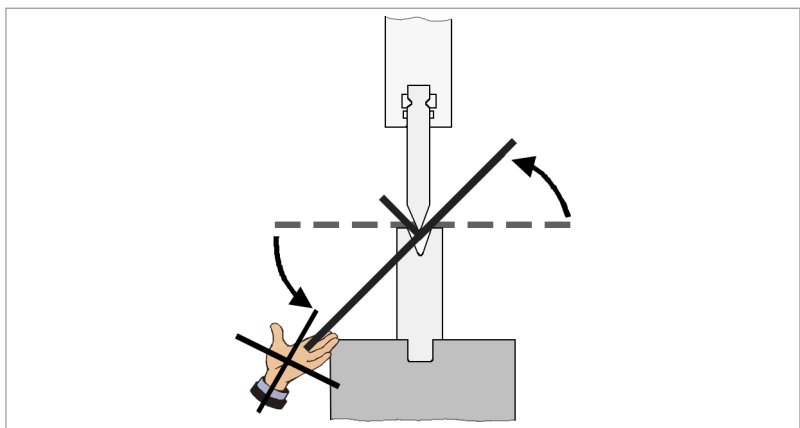

Bend internal tabs

Fig. 71123

⚠ WARNING

When bending flanges on the inside the workpiece swivels downwards!

Risk of injury, crushing!

- Maintain sufficient distance from the workpiece and from the lower tool clamp.
- Position the workpiece such that hands and fingers do not get clamped.

Positioning the workpiece

If the workpiece is incorrectly positioned, the workpiece and the gauge finger of the backgauge can collide.

⚠ WARNING

The backgauge can move unexpectedly and at high speeds!

Risk of injury!

- Position the workpiece only after the backgauge has moved to the next position.

Falling workpieces**⚠ CAUTION**

Falling workpieces!

Risk of injury!

- Wear safety shoes.

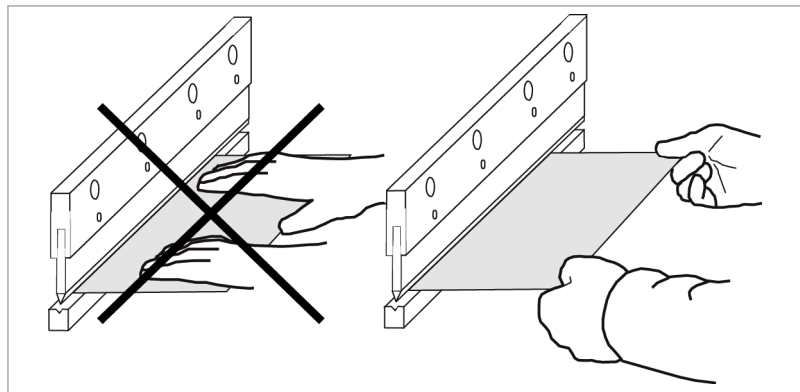
Improper handling of flat workpieces

Correctly bending flat workpiece

Fig. 77538

- Hold onto the workpiece by the front corners:
 - Thumbs lie on the workpiece.
 - Palms of hand hold the workpiece from below.

Improper handling when bending boxes

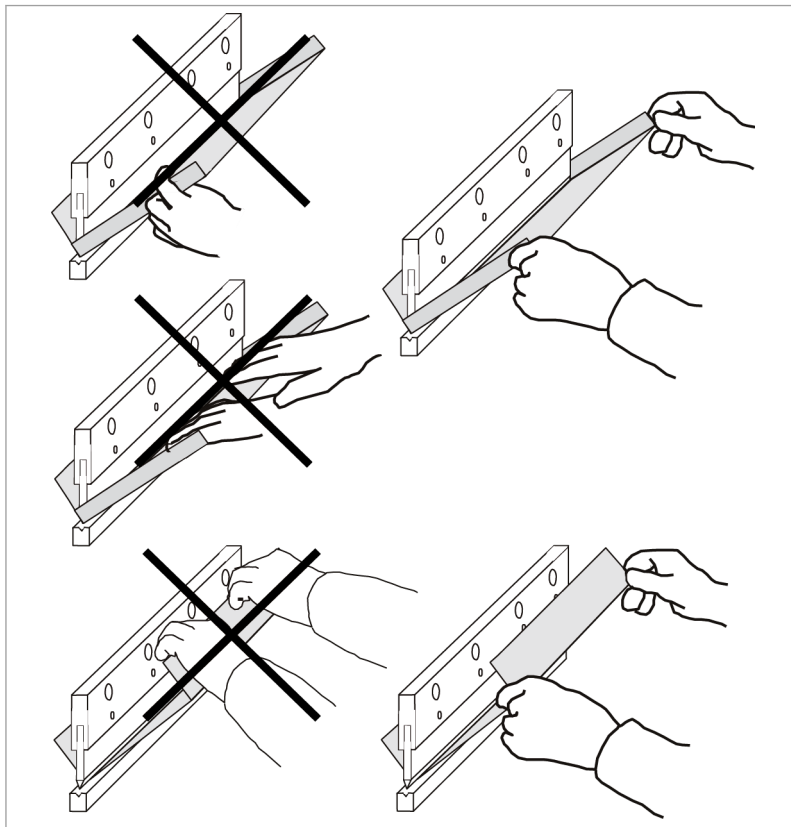

Bending box correctly

Fig. 77539

- Hold the workpiece at the right and left between your thumb and index finger.
- When holding, do not reach into the box with your hands. Due to the bending operation, fingers or your hand can be crushed or caught between the workpiece and upper tool.

Dangers when dealing with tools

CAUTION

A collision of the backgauge fingers of the backgauge with loaded tools is possible.

- The positions of the X and R axes currently programmed in the manual mode must be suitable for the loaded tools **or**
- adjust the position of the X axis to **>500 mm or**
- remove the loaded tools.

⚠ WARNING**Risk of injury from falling tools due to inadequate securing measures!**

- Before each tool application, and in the event of incorrect and prolonged storage, check the securing measures (Safety Click, safety pins etc.) for their functionality (signs of wear, ease of movement of the Safety Click etc., and replace if necessary).

Dangers when transporting the machine**⚠ DANGER****Suspended load!****Falling loads could lead to severe bodily injury or even death.**

- Observe safety regulations for the handling of heavy loads.
- Never walk under a suspended load.
- Use tested and appropriately sized tackle and means of transportation.
- Employ qualified technicians to transport the machine.
- Carry out transport in accordance with the transport regulations.
- Only place the machine on firm, horizontal ground, even during intermediate storage and machine changeover.

⚠ DANGER**The machine tilts forward!****Mortal danger!**

- All persons must be clear of the danger zone during machine transport.
- Only approved accessories and equipment may be used for transport and installation.
- The machine may only be transported, temporarily stored and moved when transport devices are installed.
- The following transport devices may only be removed when the machine has been firmly anchored to the foundation.
- The machine may be operated only if it is anchored firmly in the foundation.

6.2 Dangers from electricity

Work on electrical equipment and live parts is only allowed to be carried out by trained qualified personnel.

Dangers due to the open electrical cabinet

The electrical cabinet may be opened only by an electrician.

**DANGER**

Electrical voltage!

Electric shock!

- Keep the electrical cabinet closed.
 - Before opening the electrical cabinet: turn off the MAIN SWITCH and secure it against being switched back on again. Wait for the discharging time (at least 15 minutes).
-

**CAUTION**

Hot components!

Burns!

- Keep electrical cabinet closed.
 - Before opening the electrical cabinet: switch off the main switch and secure against being switched back on.
 - Wait for the cooling phase (minimum 5 minutes).
-

6.3 Thermal dangers

Dangers due to fire

**WARNING**

Fire!

Serious injuries.

- In the event of fire, leave the danger zone and take fire protection measures.
-

Fire hazard

Firefighting must be performed only by personnel who are trained to do so and who are using appropriate protective equipment. If there is a risk of self-endangerment, or if the fire threatens to escalate, the fire department must be called.

The following extinguishing agents should be kept ready for fire protection:

- CO₂ hand-held fire extinguisher (fire classification B, 5 kg) for fires at the machine (except for metal fires).
- Hand-held fire extinguisher for metal fires [fire classification D, 12 kg (26 lb)].
- Metal bucket (at least 20 l) with dry sand.

Extinguishing fire on the machine

Means, Tools, Materials

- CO₂ hand-held fire extinguisher [fire classification B, 5 kg (11 lb)] for fires in the compact dust extractor and for fires at the machine (except for metal fires).
- Hand-held fire extinguisher for metal fires [fire classification D, 12 kg (26 lb)].

or

- Metal bucket (at least 20 l) with dry sand.

WARNING

Risk of burns from flames and hot components!

- Wear protective gloves and safety glasses.
- Only touch hot components with protective gloves.

1. Press the EMERGENCY STOP push-button.
2. Switch off the MAIN SWITCH of the machine.
3. Extinguish the fire from a safe distance using sand or with the correct hand-held fire extinguisher.

6.4 Noise hazards

The A-weighted emission sound pressure at the work station of the personnel is at ≤ 70 dB(A).

6.5 Hazards due to laser radiation

Optoelectronic safety device The optoelectronic safety device corresponds to laser class 1.

6.6 Combination of dangers

Hazards due to remote support

Remote support is used to establish a connection between the machine and Technical Service.

The service engineer can access the user interface to analyze problems and in some cases to eliminate them directly.

 **WARNING**

Activated remote support!

Injury and damage to property.

- Only persons trained by TRUMPF may take part in a remote support session.
 - If doubts arise regarding the qualifications of the persons involved or if comprehension issues arise, TRUMPF can refuse remote support or terminate the remote support session.
-

Dangers when using a bending foil

Bending foil can be placed over the lower tool to prevent impressions on the workpiece.

 **WARNING**

Travel motion of the backgauge with automatic step change!

Risk of getting caught between the bending tool and the backgauge.

- Always press the EMERGENCY STOP push-button before clamping a bending foil.
-

Dangers during maintenance work

 **DANGER**

Risk of fatal injury during maintenance work with the machine switched on!

- If not expressly described differently: Correctly switch off the machine, switch off the MAIN SWITCH and secure with a padlock.
 - Strictly adhere to the safety regulations.
-

⚠ CAUTION**The leaning ladder could tip over!**

- For maintenance work that requires climbing equipment, use a stepladder.

⚠ WARNING**Hot oil (up to 70 °C) during maintenance work immediately after machine operation****Risk of burns.**

- Apply appropriate safety measures.
- Wait until the oil has cooled down.

Dangers when dealing with burst hydraulic system hoses

Hydraulic system hoses age or can become damaged due to use. Aged and damaged hydraulic system hoses are dangerous.

⚠ DANGER**Injury due to a hydraulic system hose bursting and thrashing around!**

- Check all hydraulic system hoses in accordance with the maintenance instructions.
- When in doubt, replace the hydraulic system hose.

7. Measures to be taken by the manufacturer

7.1 Danger zones and safeguarding



Danger zone and safeguarding

Fig. 102832

Side safety doors

These safety doors safeguard the area to the side of the press beam and machine bed. When the doors are closed, it is not possible for persons to reach into the danger zone from the side.

The side safety doors are monitored.

If **both** of the side safety doors are opened during operation, it leads to the following:

- EMERGENCY STOP is triggered.
- The PRESS BEAM UP foot switch is deactivated.

If **one** of the side safety doors is opened during operation, it leads to the following:

- Axes movement stops.

Rear safety door The safety door secures the danger zone inside the machine. The safety door is monitored. If the safety door is opened during machining, EMERGENCY STOP will be triggered.

BendGuard optoelectronic safety device The optoelectronic safety device monitors the area in front of, behind and below the upper tool during operation by means of a light field. The press beam moves at a maximum speed between the upper dead point and the mute point. If the BendGuard is pushed up by an obstacle (e.g. trapped hand) or if the light field is interrupted, then the press beam will stop. The press beam moves at reduced speed between the mute point and the lower dead point. The optoelectronic safety device is not active.

Machine main switch The main switch is used to switch the machine on and off. The main switch can be secured with a padlock against being switched back on again.

The main switch has two switch settings:

Switch setting 0	The machine is switched off and the voltage supply of the machine is interrupted .
Switch setting 1	The machine is switched on.

Tab. 1-4

EMERGENCY STOP push-button/EMERGENCY STOP function EMERGENCY STOP has the following effect:

- Control stops.
- The press beam stops.
- Stop all axis motions of the backgauge.
- The PRESS BEAM UP foot switch is deactivated.
- All drives of the backgauge remain supplied, but cannot generate any power (STO: safe torque off).
- The hydraulic unit is switched off.

**NEC version of electrical cabinet (NAFTA):
DEACTIVATE ELECTRICAL CABINET DOOR VOLTAGE INTERRUPTION key switch (Service)**

For maintenance work in an energized electrical cabinet, there is a key switch which deactivates the automatic voltage interruption.

The key switch is located on the rear side of the machine.

The key switch has the following positions:

Position	Description
0	The power supply to the machine will be interrupted when the switching cabinet door is opened. The key must be removed and kept safely.
I	The power supply to the machine remains switched on when the electrical cabinet door is opened.

Tab. 1-5

PRESS BEAM DOWN foot switch with stop function

The foot switch has the following positions:

Position	Description
The foot switch is not pressed.	The press beam is stationary or remains stationary.
The foot switch is pressed as far as the first pressure point (neutral position).	The press beam moves downwards.
The foot switch is pressed all the way down.	The stop function leads to the following: <ul style="list-style-type: none"> ▪ Control stops. ▪ The press beam stops. ▪ Stop all axis motions of the backgauge. ▪ The hydraulic unit is switched off.

Tab. 1-6

PRESS BEAM UP foot switch

The press beam can be moved upwards using the PRESS BEAM UP foot switch.

The foot switch has the following positions:

Position	Description
The foot switch is not pressed.	No effect on the press beam.
The foot switch is pressed.	Hydraulic system switches on. The press beam moves upwards.

Tab. 1-7

The PRESS BEAM UP foot switch is not active in the following cases:

- EMERGENCY STOP was triggered.
- One or both side protection doors were opened.
- The rear safety door was opened.

**USA, Canada, Mexico,
South America
Key switch
for DEACTIVATE DOOR
LOCK**

There is a key switch for the maintenance work performed by trained personnel. The key must be removed and kept safely.

The key switch is located on the rear side of the machine and has two positions:

Switch setting 0	The power supply to the machine will be interrupted when the switching cabinet door is opened.
Switch setting 1	The power supply to the machine remains switched on when the electrical cabinet door is opened.

Tab. 1-8

**Processing strategy of the
backgauge**

The backgauge can move to the next programmed position at different times.

Step change	Description
Manually	the press beam moves to the upper dead point (UDT). The control stops. The backgauge moves to the next index position when START is pressed.
	the press beam moves to the upper dead point (UDT). The backgauge moves to the next index position when the PRESS BEAM DOWN foot switch is pressed.

Step change

Tab. 1-9

Monitoring of BendGuard

The BendGuard is installed such that it can be raised by 25 mm. If the BendGuard is raised due to an obstacle (e.g. trapped hand) during the bending process, the press beam stops.

7.2 Safety-relevant signs on the machine

Warning signs draw attention to dangers when operating the machine.

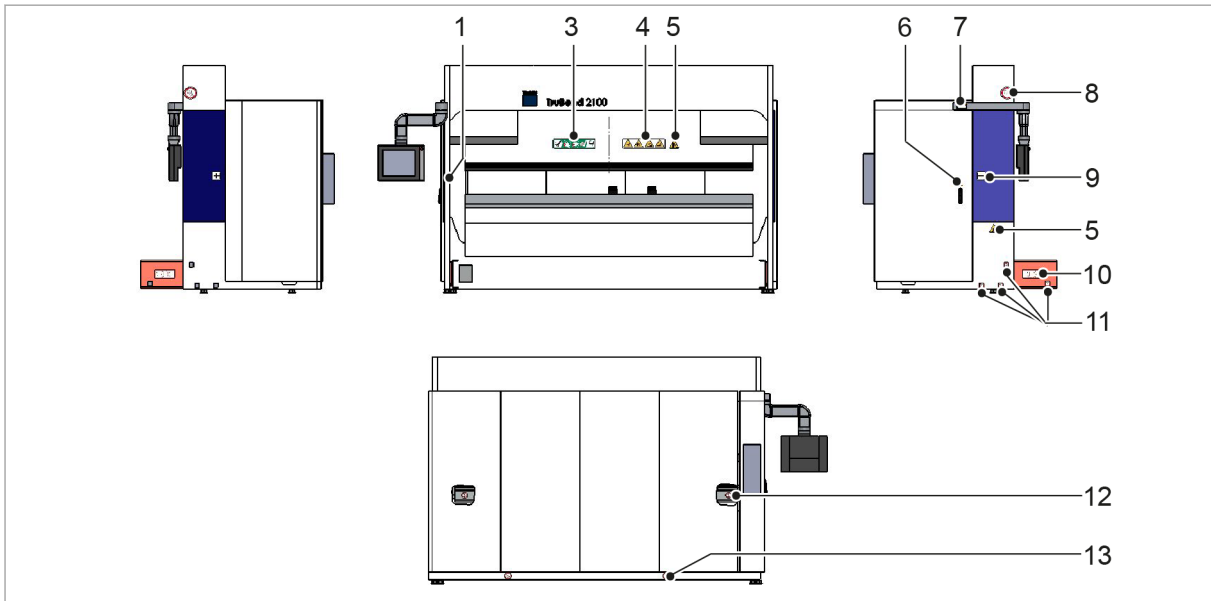

Fig. 102837

No.	Safety-relevant signs on the machine	Description
-		Warning of hot surface.
1		WARNING about laser beams.
3		Safety information for freeing trapped persons.
4		<ul style="list-style-type: none"> 1: Risk of crushing between upper and lower tool. 2: Risk of crushing between work-piece that has moved up or down and machine parts in this area. 3: Risk of impact due to workpiece that has moved up or down. 4: Risk of crushing and impact due to backgauge.
5		Risk of tilting
6		Warning about electrical voltage.

No.	Safety-relevant signs on the machine	Description
7		<p>Machine is top-heavy. Secure the machine from toppling over until it is anchored in the foundation.</p>
8		<p>Secure machine on the truck during transport.</p>
9		<p>Position of center of gravity.</p>
10		<p>Only remove the transport securing device when the machine is anchored.</p>
11		<p>Jacking point for hydraulic hoisting jack.</p>
12		<p>Climbing on prohibited.</p>
13		<p>Move the machine carefully and delicately and by hand only. Do not use a forklift truck or other motorized tractors as there is a risk of tilting due to abrupt acceleration.</p>

Safety-relevant signs on the machine

Tab. 1-10

7.3 Safety-relevant signs on the machine (USA and Canada)

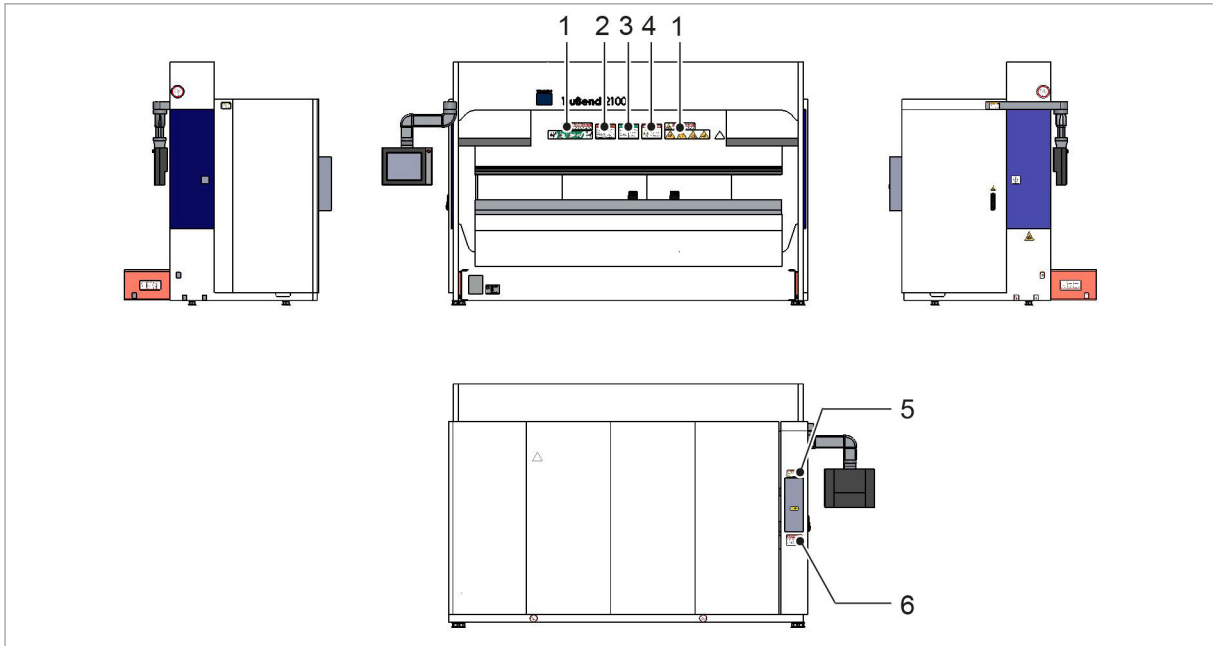

Fig. 102838

:

No.	Safety-relevant signs on the machine (USA and Canada)
1	
2	

No.	Safety-relevant signs on the machine (USA and Canada)		
3	<div style="border: 1px solid black; padding: 5px;"> <div style="background-color: #008000; color: white; text-align: center; padding: 5px;">SAFETY INSTRUCTION</div> <div style="text-align: center; padding: 5px;">PRESS BRAKE</div> <table border="0" style="width: 100%; font-size: small;"> <tr> <td style="vertical-align: top; width: 50%;"> <ul style="list-style-type: none"> • Read and understand the operation and safety manual • Know how to use the operator controls and modes of operation <p>SET UP</p> <ul style="list-style-type: none"> • Position ram at bottom of working stroke • Turn operator controls off (key lock) when working in the area • Use inch mode • To avoid splitting dies, make certain tonnage capacity of the dies are not exceeded • Provide point of operation safeguarding • Test all the operation control stations modes of operation and safeguarding • Instruct operators in proper setup • Keep all keys under supervisory control </td> <td style="vertical-align: top; width: 50%;"> <p>OPERATION</p> <ul style="list-style-type: none"> • Use point of operation safeguarding • Know the set up and proper method of operation • Test all the required operator control stations and modes of operation before each shift, each job run and after each break • Keep hands out of die area (point of operation) • Do not position any part of your body where it may be struck or crushed by part movement • Use hand tools for small or narrow piece parts • Make certain everyone is clear of press brake dies and material before operating • Turn off or lockout operator controls when not operating press brake • When you leave this press brake <ul style="list-style-type: none"> • Position ram at bottom of working stroke • Turn off or lockout operator controls • Turn power off </td> </tr> </table> <div style="display: flex; justify-content: space-between; font-size: x-small; margin-top: 5px;"> DO NOT REMOVE THIS SIGN FROM THIS PRESS BRAKE 2247903 </div> </div>	<ul style="list-style-type: none"> • Read and understand the operation and safety manual • Know how to use the operator controls and modes of operation <p>SET UP</p> <ul style="list-style-type: none"> • Position ram at bottom of working stroke • Turn operator controls off (key lock) when working in the area • Use inch mode • To avoid splitting dies, make certain tonnage capacity of the dies are not exceeded • Provide point of operation safeguarding • Test all the operation control stations modes of operation and safeguarding • Instruct operators in proper setup • Keep all keys under supervisory control 	<p>OPERATION</p> <ul style="list-style-type: none"> • Use point of operation safeguarding • Know the set up and proper method of operation • Test all the required operator control stations and modes of operation before each shift, each job run and after each break • Keep hands out of die area (point of operation) • Do not position any part of your body where it may be struck or crushed by part movement • Use hand tools for small or narrow piece parts • Make certain everyone is clear of press brake dies and material before operating • Turn off or lockout operator controls when not operating press brake • When you leave this press brake <ul style="list-style-type: none"> • Position ram at bottom of working stroke • Turn off or lockout operator controls • Turn power off
<ul style="list-style-type: none"> • Read and understand the operation and safety manual • Know how to use the operator controls and modes of operation <p>SET UP</p> <ul style="list-style-type: none"> • Position ram at bottom of working stroke • Turn operator controls off (key lock) when working in the area • Use inch mode • To avoid splitting dies, make certain tonnage capacity of the dies are not exceeded • Provide point of operation safeguarding • Test all the operation control stations modes of operation and safeguarding • Instruct operators in proper setup • Keep all keys under supervisory control 	<p>OPERATION</p> <ul style="list-style-type: none"> • Use point of operation safeguarding • Know the set up and proper method of operation • Test all the required operator control stations and modes of operation before each shift, each job run and after each break • Keep hands out of die area (point of operation) • Do not position any part of your body where it may be struck or crushed by part movement • Use hand tools for small or narrow piece parts • Make certain everyone is clear of press brake dies and material before operating • Turn off or lockout operator controls when not operating press brake • When you leave this press brake <ul style="list-style-type: none"> • Position ram at bottom of working stroke • Turn off or lockout operator controls • Turn power off 		
4	<div style="border: 1px solid black; padding: 5px;"> <div style="background-color: #d62728; color: white; text-align: center; padding: 5px;">! DANGER</div> <div style="text-align: center; padding: 5px;"> <p>TO REDUCE THE POSSIBILITY OF INJURY... DO NOT place your hands in the die area</p> </div> <div style="text-align: center; padding: 5px;"> <p>DO NOT position any part of your body where it may be struck or crushed by part movement</p> </div> <div style="text-align: center; padding: 5px;"> <p>ALWAYS read and understand the operation maintenance and safety manual before installing bending tools, operating or servicing the press brake</p> </div> <div style="display: flex; justify-content: space-between; font-size: x-small; margin-top: 5px;"> DO NOT REMOVE THIS SIGN OR MANUAL FROM THIS MACHINE 2247567 </div> </div>		
5	<div style="border: 1px solid black; padding: 5px;"> <div style="background-color: #ff9900; color: black; text-align: center; padding: 5px;">! WARNING</div> <div style="text-align: center; padding: 5px;"> <p>HAZARDOUS VOLTAGE Contact may cause electric shock or burn. Turn off and lock out system before servicing.</p> </div> <div style="text-align: center; padding: 5px;"> <p>ARC FLASH & SHOCK HAZARD Follow all requirements in NFPA 70E for safe work practice and for personal protective equipment while working on this energized system.</p> </div> <div style="display: flex; justify-content: space-between; font-size: x-small; margin-top: 5px;"> DO NOT REMOVE THIS SIGN OR MANUAL FROM THIS MACHINE 2247889 </div> </div>		
6	<div style="border: 1px solid black; padding: 5px;"> <div style="background-color: #d62728; color: white; text-align: center; padding: 5px;">! DANGER</div> <div style="text-align: center; padding: 10px; font-size: large;"> <p>Keep out of this area while main switch is ON</p> </div> <div style="display: flex; justify-content: space-between; font-size: x-small; margin-top: 5px;"> DO NOT REMOVE THIS SIGN FROM THIS MACHINE 2247905 </div> </div>		

Safety-relevant signs on the machine (USA and Canada)

Tab. 1-11

8. Organizational measures to be taken by the user

The user must take the following measures before starting working on the machine:

- Perform a risk assessment in accordance with national regulations. To create the risk assessment the section "Dangers" and all warnings in the operator's manual must be taken into account.
- Define which personnel are responsible for safety, operation, maintenance, setting work and service.
- Provide personal protective equipment (for example, protective gloves, safety shoes, hearing protection, safety glasses).

8.1 Training and instructing operators

The user must take the following measures before the personnel start working on the machine:

- Inform personnel about possible dangers and safety measures. Chapter 1 "Safety" forms the basis.
- Personnel are obligated to read the technical documentation of the machine. Recommendation: obtain written confirmation from the personnel.
- Instruct personnel that warnings and warning signs are to be observed.
- Ensure personnel wear personal protective equipment (for example, protective gloves, safety shoes, hearing protection, safety glasses).

8.2 Due diligence when operating the machine

The user is obligated to ensure the operational safety of the machine according to national regulations. Among others, the following measures must be taken:

- Ensure that only authorized personnel works at the machine.
- Ensure that maintenance work is carried out according to the prescribed intervals.
- Ensure that regular visual inspections are carried out on components that could jeopardize operational safety if damaged (e.g. hydraulic system hoses, pressure containers, etc.).
- Make sure that damaged or missing warning signs on the machine are replaced.

- Ensure that the machine is clean and uncluttered.
- Ensure a sufficient fresh air supply and sufficient lighting in the work areas.

Checking danger zone and guards

The personnel must ensure that only those people who are absolutely required for operation may be in the immediate danger zone (up to 1 meter in front of the bending line over the entire length of the press table).

Personnel are only allowed to operate the machine with functional guards. Guards are not allowed to be removed or put out of operation.

Operating personnel must immediately report changes (including the operating performance) occurring in the machine to the operator.

The following guards must be checked for integrity and functionality once per shift and after a collision:

- Side safety doors: Checking the operation of the safety switch
- Rear safety door: Checking the operation of the safety switch
- EMERGENCY STOP push-button/PRESS BEAM DOWN foot switch with stop function: Check EMERGENCY STOP for correct function

Ensuring the perfect working order

Operator:

- The operator must check the machine for externally visible defects and damage at least once per shift.
- The operator must ensure that worn tools are not used.
- The operator must ensure that tools and backgauges are correctly programmed and set up for the work to be done.

Lock the machine to prevent unauthorized use

If the operator leaves the machine for a short time or at the end of the shift, he must secure the axes from moving. By entering a code on the user interface, the machine can be locked to prevent unauthorized use.

Pay attention to the user responsibilities for hydraulic system hoses

The user must observe national regulations for hydraulic system hoses.

8.3 Water protection

Water-pollutant substances should not enter the ground or into water bodies.

National regulations for water protection must be observed.

Water-pollutant materials	Volume
Lubricants	≤1000 l (≤264 gal)

Water protection specifications

Tab. 1-12

8.4 Spare parts, accessories, software, operating materials

Liability disclaimer

TRUMPF is not liable for damage if external parts and accessories are used or if spare parts and accessories approved by TRUMPF are not installed or replaced properly.

TRUMPF is not liable for damages resulting from the installation or operation of software which is not approved by TRUMPF.

Using permissible operating materials as per the regulations

The approved operating materials (especially lubricating and cleaning agents) must be used according to regulations. According to the GHS (Globally Harmonized System of Classification, Labelling and Packaging of Chemicals), a safety data sheet is required for certain operating materials.

The safety data sheet is supplied with the operating material. The data contained therein must be taken into account.

The safety data sheet can include the following data:

- Chemical properties.
- Physical and safety-related specifications.
- Transport.
- Safety measures, storage, and handling.
- Measures for in the event of accidents or fires.
- Specifications for toxicology and ecology.
- Waste code with prescribed disposal method for the operating material.

Notes

- The safety data sheet can be requested from the manufacturer of the respective operating material.
- The safety data sheets e.g. for lubricants, metal powder, cleaners or gases can be downloaded from the TRUMPF web page:
<http://www.trumpf.com/s/msds>.

8.5 Additional equipment

The following safety-tested ladder must be available for safe performance of maintenance and Technical Service operations: single ladder, length 4 meters.

9. Residual risks

The overview of residual risks is based on the manufacturer's risk assessment. The overview lists the possible hazards to life and health posed by the machine.

The machine user must take suitable measures to prevent the residual risks.

For detailed descriptions of the measures: (see "Hazards", pg. 1-11).

Residual risks	Hazard area	Type of danger	Necessary action
Mechanical elements			
Squeezing, shearing off of body parts, cutting, impacts	<ul style="list-style-type: none"> ▪ Vertical tool change. ▪ Stopping and positioning of the workpieces. 	Risk of injury	<p>Operation by trained and instructed personnel.</p> <p>Wear personal safety equipment.</p> <p>If body parts are trapped, press the PRESS BEAM UP foot switch.</p>
Gripping or retracting Squeezing, shearing off of body parts	<ul style="list-style-type: none"> ▪ Movement of the backgauge and the workpiece. ▪ Collision between the gauge fingers and the tool. 	Risk of injury	<p>Operation by trained and instructed personnel.</p> <p>Select appropriate processing strategy of the backgauge.</p> <p>Position the workpiece only after the backgauge has moved to the next position.</p> <p>Do not reach over the bending line.</p>
Crushing	<ul style="list-style-type: none"> ▪ Between the workpiece and the press beam. 	Risk of fatal injury	Operation by trained and instructed personnel.
Rubbing or abrading	<ul style="list-style-type: none"> ▪ Movement of the press beam. 	Risk of injury	<p>Operation by trained and instructed personnel.</p> <p>Do not touch the press beam as long as it is moving.</p>
Slipping, falling	<ul style="list-style-type: none"> ▪ In case of a fault: larger oil leak from the hydraulics. 	Risk of injury	Operation by trained and instructed personnel.
Injection	<ul style="list-style-type: none"> ▪ In case of a fault: escape of high-pressure hydraulic oil. 	Risk of injury	<p>Specially trained personnel for maintenance, service and repairs.</p> <p>Observe the compulsory maintenance work requirements.</p>
Falling workpieces	<ul style="list-style-type: none"> ▪ Releasing the workpiece after bending. 	Risk of injury	<p>Operation by trained and instructed personnel.</p> <p>Wear personal safety equipment.</p>

Residual risks	Hazard area	Type of danger	Necessary action
Falling tools	<ul style="list-style-type: none"> Unintentional actuation of the Safety-Click. 	Risk of injury	<p>Operation by trained and instructed personnel.</p> <p>Wear personal safety equipment.</p>
Instability	<ul style="list-style-type: none"> Tipping over of the machine. 	Risk of fatal injury	<p>Use the intended securing points and permitted additional equipment to transport the machine.</p> <p>Anchor the machine to the floor.</p>
Radiation			
Laser	BendGuard optoelectronic safety device	Risk of injury	<p>Operation by trained and instructed personnel.</p> <p>Do not look directly into the beam.</p>
Materials			
Contact with or by inhaling dust, aerosols and gases	Hydraulic oil or lubricants	Health hazard	<p>Specially trained personnel for maintenance, service and repairs.</p> <p>Wear personal safety equipment.</p> <p>Note the safety data sheets.</p>
Electrics			
Electric contact	<ul style="list-style-type: none"> Direct contact with normally live parts. 	Risk of fatal injury	Specially trained personnel for maintenance, service and repairs.
	<ul style="list-style-type: none"> Indirect contact with parts that are live due to an error. 	Risk of fatal injury	Specially trained personnel for maintenance, service and repairs.

Residual risks

Tab. 1-13

10. Disassembly and disposal

TRUMPF recommends commissioning Technical Service or a specialist disposal company with the dismantling and disposal of a machine, component or system. The information below must be passed on to the specialist company performing the disposal work.

Preparing disassembly

The following measures must be taken to avoid dangers during disassembly:

- Lower moving assemblies and suspended loads. Secure or support defective moving assemblies and suspended loads.
- Switch off the machine, component or system and wait at least 1 hour until residual voltages have dissipated and hot components have cooled down.
- If available: shut off the compressed air and gas supply and disconnect them from the customer's system.
- Relieve the pressure in pressurized components.
- Clean away contamination, especially dust.
- Have the machine, component or system disconnected from the power supply by a trained electrician.
- Cordon off the areas in which removal and storage are taking place.

Dangers during the disassembly

Hazard	Necessary action
Toxic vapors due to thermal separation of painted components or composites.	<ul style="list-style-type: none"> ▪ Select a suitable cutting process. ▪ Wear a suitable protective mask. ▪ Ensure sufficient fresh air supply.
High or eccentric center of gravity of an assembly or machine.	<ul style="list-style-type: none"> ▪ Secure the assembly or machine against tipping. ▪ Put the assembly or machine into the transport position. ▪ Use transport securing devices to prevent tipping.
Suspended load due to assemblies that cannot be lowered.	<ul style="list-style-type: none"> ▪ Secure or support suspended load.
Moving assemblies (unbraked) after separation from the power supply system.	<ul style="list-style-type: none"> ▪ Secure movable assemblies.
Unstable assemblies after loosening connecting parts or anchors.	<ul style="list-style-type: none"> ▪ Secure unstable assemblies to prevent loosening.
Release of mechanical tension by loosening chains, ropes and other components.	<ul style="list-style-type: none"> ▪ Relieve components under tension in a controlled manner.
Residual pressure in hydraulic or compressed air systems caused by a defective machine or component.	<ul style="list-style-type: none"> ▪ Release pressure from pressurized assemblies in a proper manner.

Dangers during the disassembly

Tab. 1-14



Modules with particular risk potential

The following modules will constitute a particular hazard if disassembled:

Assembly	DANGER
Machine	Can tilt forwards if the brace is released.
Press beam	Falls down if the hydraulic components are removed first.

Tab. 1-15

Hazardous materials

Dispose of the following hazardous materials in accordance with national regulations:

Hazardous substance	Occurrence
Hydraulic oil	Hydraulic unit, hydraulic cylinder, hydraulic lines, hydraulic system hoses
Refrigerant	Air conditioning unit (electrical cabinet)
Batteries	Electrical cabinet, operating panel

Tab. 1-16

Chapter 2

TruBend Series 2000 (B35) installation conditions

	Who does what?	2-4
1	Planning aid	2-5
2	Installation site	2-6
2.1	Space requirements	2-6
2.2	Floor requirements	2-6
	Surface	2-6
	Floor quality	2-8
2.3	Weight load	2-10
2.4	Stress due to vibration	2-11
2.5	Ambient conditions	2-12
3	Electrics	2-13
3.1	Power supply	2-13
	Connected loads	2-13
	Connecting cables	2-14

3.2	Power supply	2-14
	Uninterruptible power supply (UPS)	2-14
	Residual current device (RCD)	2-15
	Power supply configurations	2-16
	Isolating transformer	2-17
3.3	Remote support	2-17
3.4	Network link	2-17
4	Operating materials	2-23
4.1	Hydraulic oil	2-23
5	Preparation for commissioning	2-24
6	Transport	2-25
6.1	Preparing transport	2-25
	Transport dimensions	2-26
6.2	Permitted auxiliary tools	2-27
6.3	Checking, unloading and transporting the machine	2-28
	Checking delivery	2-28
	Unloading and transporting the machine	2-29
6.4	Relocating the machine	2-40
	Mounting the transport securing devices	2-40
	Transporting the machine using an indoor crane	2-42
	Lifting the machine from the ground without indoor crane and transporting with armored rollers	2-43
7	Installation	2-67
7.1	Positioning the machine and drilling holes	2-67
8	Set-up and positioning	2-70
8.1	Preparing adjustable legs, positioning the machine	2-70
9	Support bracket	2-74
9.1	Assemble the support bracket	2-74
10	Foot switch and network cable	2-75
10.1	Connect the foot switch and network cable	2-75

11	Electrical connection	2-77
11.1	Connecting the power cable	2-77

Who does what?

Customer All the conditions described in this chapter must be fulfilled before the machine is delivered.

Note

During start-up, the main switch on the machine may only be switched on by Technical Service.

Technical Service The commissioning is started up by Technical Service.

The start-up includes the following:

- Align, level and secure the machine.
- If necessary, add oil.
- Connecting the machine to the power supply.
- Performing a functional test.

1. Planning aid

The planning aid provides an overview of the measures to be taken and preparations to be made.

For details, refer to the corresponding sections of these installation conditions.

Planning criterion	Required measures
Personnel and training	<ul style="list-style-type: none"> ▪ Appoint a member of staff to be responsible for preparations for the delivery of the machine. ▪ Appoint operating and service personnel and programmers. ▪ Arrange training time for qualified personnel.
Installation site	<ul style="list-style-type: none"> ▪ Determine the installation site of the machine, taking into account the space requirements according to the installation plan. ▪ Check floor requirements: <ul style="list-style-type: none"> - Floor quality. - Flatness. ▪ Take the weight and dimensions of the machine into account. ▪ Check the requirements for ambient conditions: <ul style="list-style-type: none"> - Room temperature. - Exposure to sunlight. - Purity of the ambient air. ▪ Check transport route, e.g.: <ul style="list-style-type: none"> - Gateway openings. - Doors. - Cable rack heights. - Shunting areas around corners.
Electrical system	<ul style="list-style-type: none"> ▪ Install electrical connections at the installation site. ▪ Lay the conductor cross-section and fuse protection according to the legal requirements.
Bending tools	Order your initial set of bending tools after consulting with TRUMPF.
Transport	Provide auxiliary transport equipment.
Installation	<p>Operations which must be performed by the service engineer prior to commissioning:</p> <ul style="list-style-type: none"> ▪ Transport the machine to the installation site ▪ Position the machine correctly and prepare it for anchoring on the ground ▪ Position the adjustable legs under the machine ▪ Assemble the support bracket ▪ Connect the foot switch and network cable ▪ Have a qualified electrician connect the machine to the power supply system.

Planning aid

Tab. 2-1

2. Installation site

What does the customer need to do?

Please consult a structural analyst for professional support, particularly in the context of the topic of floor requirements. Hand over the "Installation site" section and the installation plan to the structural analyst.

2.1 Space requirements

The following is documented in the TRUMPF installation:

- Space requirements for installation.
- Space requirements of the moving elements.

Hall height	TruBend	Height of the machine	Hall height
	2100	max. 2437 mm (max. 96 in)	min. 3500 mm (min. 138 in)

Hall height

Tab. 2-2

2.2 Floor requirements

The quality of the prepared parts can be guaranteed only when the floor conditions meet TRUMPF requirements.

Surface

Flatness The floor on which the machine stands must be even.

Permissible flatness deviation (flatness tolerance):

- Footprint range: max. 12 mm (½ in) per 10 m (33 ft).
- Load-bearing points range: max. 2 mm (0.08 in) per 0.5 m (1.64 ft).

The flatness tolerance can be determined for different measuring point distances from the following diagram.

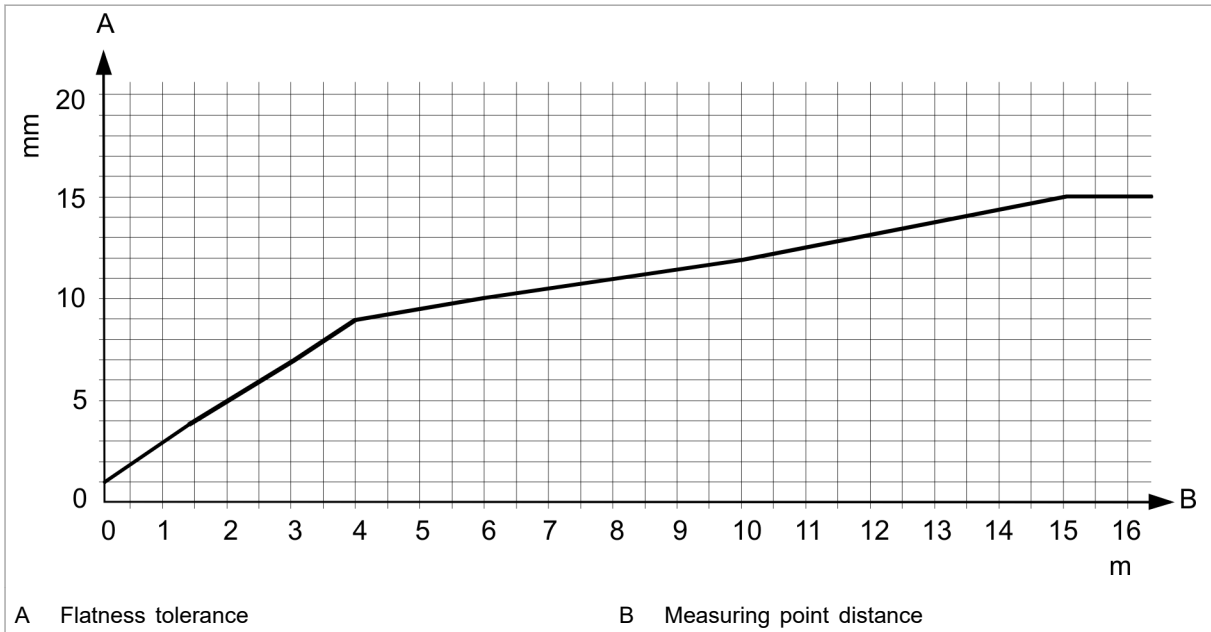

Flatness tolerance depending on the measuring point distance

Fig. 65278

Measuring point distance	Flatness tolerance	Area
0.5 m (1.64 ft)	2 mm (0.08 in)	Load-bearing points.
10 m (33 ft)	12 mm (½ in)	Installation surface.

Examples

Tab. 2-3

Measuring procedure:

The straight edge is placed on the high points of the surface and determines the depth gauge at the lowest point. For the selected measuring point distance the depth gauge may not be greater than the flatness tolerance.

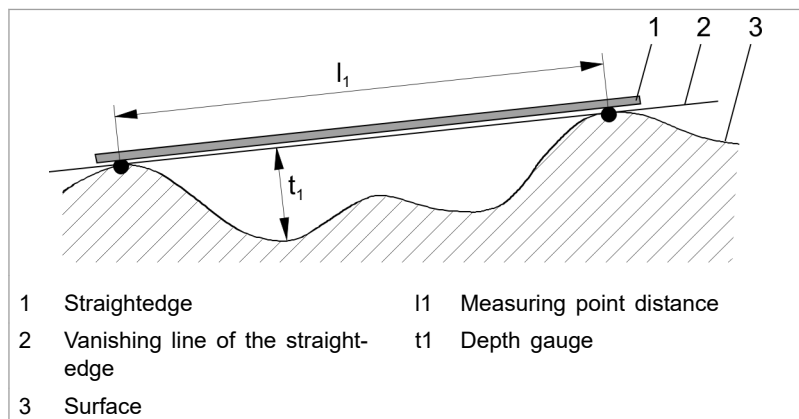

Measuring procedure for determination of the depth gauge

Fig. 65581

Floor quality

The bend quality and machine behavior can be positively influenced by a sufficiently good floor construction. It is not only important to ensure that the base plate has sufficient carrying capacity, but also that settling is kept to a minimum. Due to the machine moving in a highly dynamic manner, uneven settling of the machine leg foundation can occur.

Note

If the minimum values for the foundation cannot be reached, the bend quality and service life of the bending machine may be negatively influenced.

Foundation carrying capacity

To guarantee the carrying capacity of the foundation and keep settling and deformations of the base plate to a minimum in a newly installed floor, the following specifications apply:

- The strength of the surface of the foundation upon which the concrete slab rests is defined by the deformation modules by the plate load test in accordance with DIN 18134/EN ISO 22476-13. Load plate diameter DN300 mm.
- Deformation module $E_{v1} = 75 \text{ MN/m}^2$.
- E_{v2}/E_{v1} compression ratio ≤ 2.20 .
- Elastic cushioning $k_s = 25 - 30 \text{ MN/m}^3$.

Expansion joints

- The entire installation surface must not have any expansion joints.
- No joint of any kind may be located in the load-bearing point range of the machine or within at least 500 mm (20 in) of it.
- The distance of the plug bore holes to the edge of the base plate must be at least 200 mm (8 in).
- ToolMaster (option for TruBend 5000): if foundations are present, the arrangement of the expansion joints must be paid attention to.

Elastically cushioned base plate

- Concrete quality equivalent to strength class C 25/30.
- The floor must be oil-proof (only in the case of hydraulic tool clamp, optional).
- Reinforcement steel B500, (yield strength 500 N/mm^2).
- The design of the base plate should meet or exceed the following specifications:

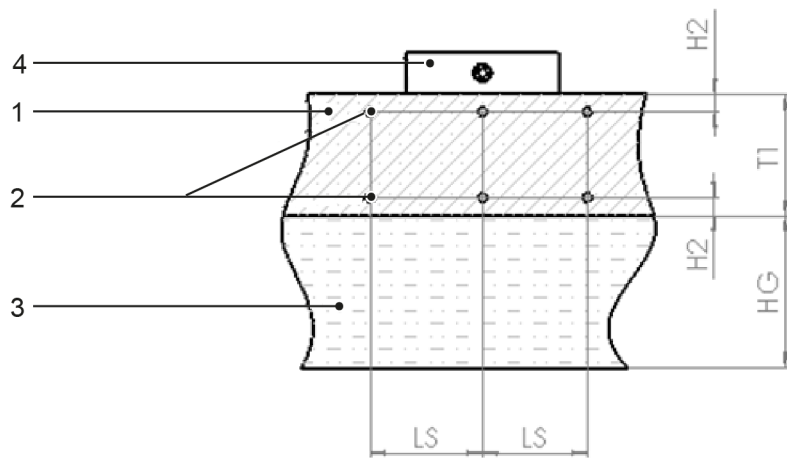
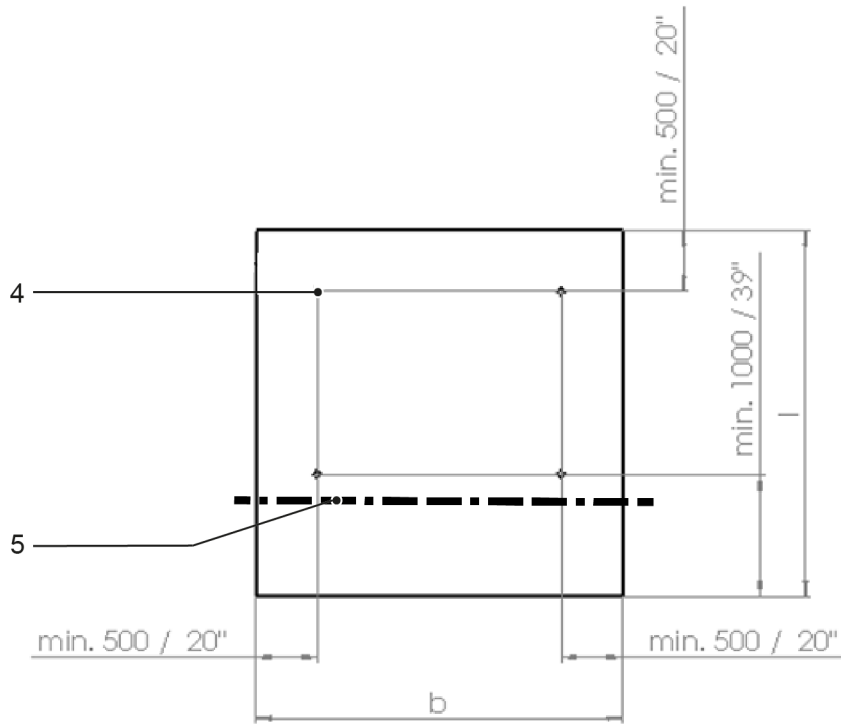

- | | | | | | |
|---|-------------------------------|---|-------------------|---|--------------|
| 1 | Concrete slab | 3 | Foundation | 5 | Bending line |
| 2 | Reinforcement above and below | 4 | Levelling element | | |

Installation surface

Fig. 113740

The dimensions of the base plate, where the permitted deformation at the machine legs is adhered to (assuming an even substrate carrying capacity).

TruBend		TB2100	TB2100 opt ¹
Minimum base plate width	b	≥ 430 cm ≥ 170"	≥ 430 cm ≥ 170"
Minimum base plate depth	l	≥ 240 cm ≥ 95"	≥ 240 cm ≥ 95"
Minimum base plate thickness	T1	≥ 20 cm ≥ 8"	≥ 15 cm ≥ 6"
Foundation	HG	See substrate carrying capacity	
Number of reinforcement layers ²		2	
Maximum distance of the reinforcement bars	LS	≥ 15 cm ≥ 6"	
Edge spacing of the reinforcement layer	H2	3 cm 1.2"	3 cm 1.2"
Upper reinforcement		3.20 cm ² /m 0.16 in ² /ft	3.20 cm ² /m 0.16 in ² /ft
Lower reinforcement		5.35 cm ² /m 0.26 in ² /ft	3.65 cm ² /m 0.18 in ² /ft

Reinforcement in the base plate: (X) = extended installation height, (S) = extended length, (SX) = extended installation height/length Tab. 2-4

When is a structural analyst generally required?

A structural analyst must be consulted under the following conditions:

- The previously mentioned requirements for an elastically embedded base plate are not met.
- The system is to be set up on a ceiling plate/free-span base plate.
- The system is to be set up on fiber-reinforced concrete or roller-compacted concrete.
- The system is to be installed on a floor other than the one named above.

2.3 Weight load

Structural analysis

- For unclear floor requirements: Perform a structural stress analysis of the load-bearing capacity of the floor surface prior to installation.
- Take into account the weights of the relevant components and the load on the support points.

1 optional installation variant: if using the optional wedge mount set (Mat. no.: 2612957; 4x wedge mounts DK -2/10) instead of the standard leveling spindles (Mat. no.: 1601821). NOTICE: Must be ordered separately.

2 crosswise installation (90°) of the reinforcement bars per reinforcement layer.

Note

If the concrete floor and reinforcement meets the **minimum thickness and concrete quality**, it will not have to be subject to a structural check.

TruBend	2100
Weight of machine	7500 kg (16534 lb)
Static load on each support point, front	32.8 kN
Dynamic load per front support point	40.9 kN
Static load on each support point, rear	5.7 kN
Dynamic load per rear support point	6.2 kN
Weight support at the front per base on a surface area of ...	80 x 80 mm (3.2 x 3.2 in)
Weight support at the rear per base on a surface area of ...	80 x 80 mm (3.2 x 3.2 in)

Weight load: (X) = enlarged open height

Tab. 2-5

2.4 Stress due to vibration

Installation of the machine with vibration damping is only necessary in special cases.

Note

Vibration damping must always be calculated and designed by a specialist for the specific application case, otherwise the risk of a deterioration of the vibration values is too great.

Vibration stress effects on the system

In the immediate area around the system, external influences can lead to stress due to vibration. Stress due to vibration can effect the quality of workpieces. Installation of the machine with vibration damping is only necessary if the following external influences (as examples) are present:

- Forklifts, factory transport units, crane tracks, railways.
- Installation or removal of other machines in the immediate vicinity of the system.
- Machines which generate vibrations during operation, such as punching presses.

Outgoing stress due to vibration from the system

Installation of the machine with vibration damping is only necessary if there are impermissible vibrations emanating from the machine.

Examples:

- In the vicinity of the machine, other machines are set up that cannot work properly due to excessive vibration stress of the bending machine.
- Adjacent office rooms.
- The bending machine stands on a ceiling. Resonance check required.

2.5 Ambient conditions

Machine ambient conditions **Note**

When installing the machine, make sure that the optoelectronic safety device BendGuard is protected against excessive drafts or temperature fluctuations. Drafts between the transmitter and receiver can lead to sporadic error messages of the BendGuard and thus influence productivity.

Machine status	Temperature
Operation	+10 °C ... +40 °C (+50°F ... +104°F)

Machine ambient conditions

Tab. 2-6

Ambient conditions for the control system

Control status	Temperature	Humidity
Transport or switched-off machine	-20 °C ... +70 °C (-4°F ... +158°F)	20 to 75 % relative humidity 90 % temporarily, but non-condensing

Ambient conditions for the control system

Tab. 2-7

3. Electrics

Target group The specifications in the "Electrical" section must be implemented by a company which specializes in electrical installations.

IEC/NEC conditions The IEC conditions apply worldwide, the NEC conditions apply only to Canada and the USA.

3.1 Power supply

Symbol in the installation plan



Fig. 29327

Note

The central connection point is on the electrical cabinet and is shown on the installation plan with the illustrated symbol.

Connected loads

Notes

- Impermissible voltage fluctuations endanger the faultless operation of the machines and reduce their performance. A voltage stabilizer is necessary.
- The tolerance range applies to brief fluctuations. Measures to stabilize the mains must be taken in the event of continually non-permitted fluctuations. These measures must be coordinated with the energy supplier.

Rated power:	Frequency
400 V $\pm 10\%$ ³	50 Hz $\pm 1\%$
460 V $+10\%/-5\%$ ⁴	60 Hz $\pm 1\%$

Nominal voltage and Frequency

Tab. 2-8

Before shipping, the system is set to the power supply voltage and frequency specified by the customer.

³ The tolerance of the line must be determined if the nominal voltage is 380 V or 415 V at 50 Hz. No isolating transformer is required if the tolerance is between 360 V and 440 V.

⁴ Specification complies with the American National Standard (ANSI), C84.1 table 1, "Voltage range A".

TruBend	2100
Connected load (IEC)	20 kVA
Connected load (NEC)	24 kVA
Fuse protection	3 x 50 A
Maximum interruption time	10 ms/10 s

Connected loads

Tab. 2-9

NEC conditions for fuses The use of slow-blow fuses is preferred. If these fuses are also used for branch circuits, an ETI type fuse must be used to protect the machine from current peaks when switching the machine on.

SCCR value The SCCR value is 35 kA.

Connecting cables

NEC	
Electrical line	<ul style="list-style-type: none"> ▪ Copper line, four-core (L1, L2, L3, PE). ▪ THHN copper or equivalent is recommended (2000 V test voltage) designed for a maximum temperature of +90° C (+194° F). ▪ No aluminum lines may be used for the machine connection.
Conductor cross-section	<ul style="list-style-type: none"> ▪ The conductor cross-section must meet NEC 670-4 (a). The conductor cross-section must be designed for at least 125 % of the nominal current. The nominal current is specified on the nameplate. ▪ To ensure voltage stability and rating, the line dimension should be larger than specified in the NEC table 310-16. ▪ Max. AWG 2

Requirements for the connecting cable

Tab. 2-10

3.2 Power supply

Uninterruptible power supply (UPS)

The following applies in the event that it is necessary to connect the system to an uninterruptible power supply (UPS):

- When working out the dimensions of the UPS, the short-circuit and overload responses of the UPS system are to be taken into account alongside the continuous power and the electrical connected loads.
- As a rule: overload capacity of the UPS $\geq 200\%$ for 0.5 s.

Note

The dimensioning of the uninterruptible power supply must be established without fail by the manufacturer of the UPS plant!

Residual current device (RCD)**Notes**

- Whether a residual current circuit breaker has to be used depends on the local electricity company.
- On the line side, only residual current circuit breakers of type B (sensitive to all types of fault current, EN 50178/5.2.11.2; VDE 0160) are approved.

A fault current circuit breaker provides protection from fault currents due to directly or indirectly touching live parts.

Residual current circuit breaker for direct contact

If a fault current circuit breaker is used to provide protection from direct contact, an isolating transformer must be used (EN 50178 section 5.2.11.1, VDE 0160). This is because the leakage current resulting from the design is >30 mA.

Fault current circuit breaker for indirect contact

If a fault current circuit breaker is to be used to provide protection from indirect contact, this must be selected depending on the machine's fault current.

Note

In rare cases, user-side voltage fluctuations on the machine's power input filter may lead to higher leakage currents than the typically specified value. The main power supply system and the machine must then be separated by an isolating transformer. Typical leakage currents are 300 mA.

If a fault current circuit breaker is used, observe the following requirements:

Characteristic	Requirement
Back-up fuse	(see "Tab. 2-9", pg. 2-14)
Fault current circuit breaker	63 A / 300 mA
Min. permissible cross-section	10 mm ²

Tab. 2-11

TRUMPF recommends the following fault current circuit breaker:

- Doepke: DFS 4B SKS 63-4 / 0.3

Power supply configurations

A TN system with grounded star point is the standard power supply configuration for the connection.

When connecting the machine to a power supply system with a grounded line conductor, an isolating transformer must be used.

For IT and TT systems, as well as for asymmetrical power supply systems (line conductor grounded, corner-grounded delta network), the machine must be connected via an isolating transformer by the user

NEC conditions Power supply configuration:

- A mains supply in star connection and with a grounded star point (Solidly Grounded Wye) is required.
- If the existing power supply system is in delta connection (Corner Grounded Delta), the user must install a grounded isolating transformer in star connection (with grounded star point) (see NEC item 450-5).

Grounding:

- The machine and power distributor system must be equipped with a grounding cable in accordance with NEC article 250, "Grounding".
- For details on grounding power distributor systems and industrial plants, refer to the NEC standards or consult an electrician or the power station.

Overvoltage protection (SPD):

- The machine contains safety circuits. Additional requirements for the electrical equipment regarding overvoltage protection must be taken into account by the user in accordance with locally applicable standards/regulations.

IT system

A surge diverter is required if the machine is connected to an IT system.

TRUMPF recommends surge diverters from the following manufacturers:

- Phoenix Contact GmbH & Co. KG, Flachsmarktstrasse 8, 32825 Blomberg, Germany e-mail: info@phoenixcontact.com.
- Dehn+Söhne, PO Box No. 1640, D-92306 Neumarkt, E-mail: info@dehn.de.

Isolating transformer

Depending on the machine and on the power supply system at the installation site, the voltages can be adjusted in the electrical cabinet at the 3-phase power supply (= EP.EM +CB1 –T2) for 3x 360 V, 3x 380 V, 3x 400 V, 3x 420 V, 3x 440 V, 3x 460 V, 3x 480 V, 3x 500 V and 3x 520 V.

3.3 Remote support

Symbol for the remote support connection point



Fig. 29332

Notes

- The connection point is indicated on the installation plan using this symbol.
- The connection point can be found in the machine's electrical cabinet.

Remote support via Internet

Note

As a result, the machine electrical cabinet is fitted with a Telepresence Box.

- A LAN cable with an RJ45 plug must be supplied to connect the machine to the user's network.
- The machine must be configured via TCP-IP to enable access to the user network.
- The machine must be able to connect to the TRUMPF Telepresence portal via the user network and the Internet. The connection is made via IPsec using the standard ports UDP 500 and UDP 4500.
- The firewall access rules should not be automatically deactivated due to longer periods of non-use.

3.4 Network link

- If a VLAN (Virtual Local Area Network) is to be set up, use only a port-based (untagged) VLAN.
- Secure communication via a proxy server is only possible if no SSL Interception is carried out by the proxy. Any alterna-

tive procedure is only permissible after consultation with TRUMPF.

- TRUMPF recommends the following:
 - Only operate TRUMPF machines in segmented networks.
 - Execute processing programs within the network in a demilitarized zone. The machine must not be allowed to access the customer's IT network.
 - Limit the communication possibilities between machines in the OT network to what is necessary.

Electrical cabinet interface An RJ45 interface is provided in the machine electrical cabinet for the network connection.

- Providing power supply**
- Worldwide (outside the USA and Canada): 230 V with grounded socket or in accordance with the receptive national standard. The grounded coupling is delivered with the machine.
 - USA and Canada: 115 V with plug socket according to USA standard.

Network settings on the DELEM control All network settings are made completely in the input mask created by DELEM under *>Settings, >Network*. All settings can be entered with the touchscreen of the DELEM control or with keyboard and mouse plugged into the DELEM control via a USB hub.

If a remote support IPC is installed, the IP address is **172.29.102.96**, the subnet mask **255.255.0.0** and the IP address of the remote support IPC **172.29.102.1** entered as the default gateway.

The domain name is defined by the customer. The entry 'corp.trumpf.com' is simply an example that is only valid within the TRUMPF Group. The remote support IPC then works as a NAT Router.

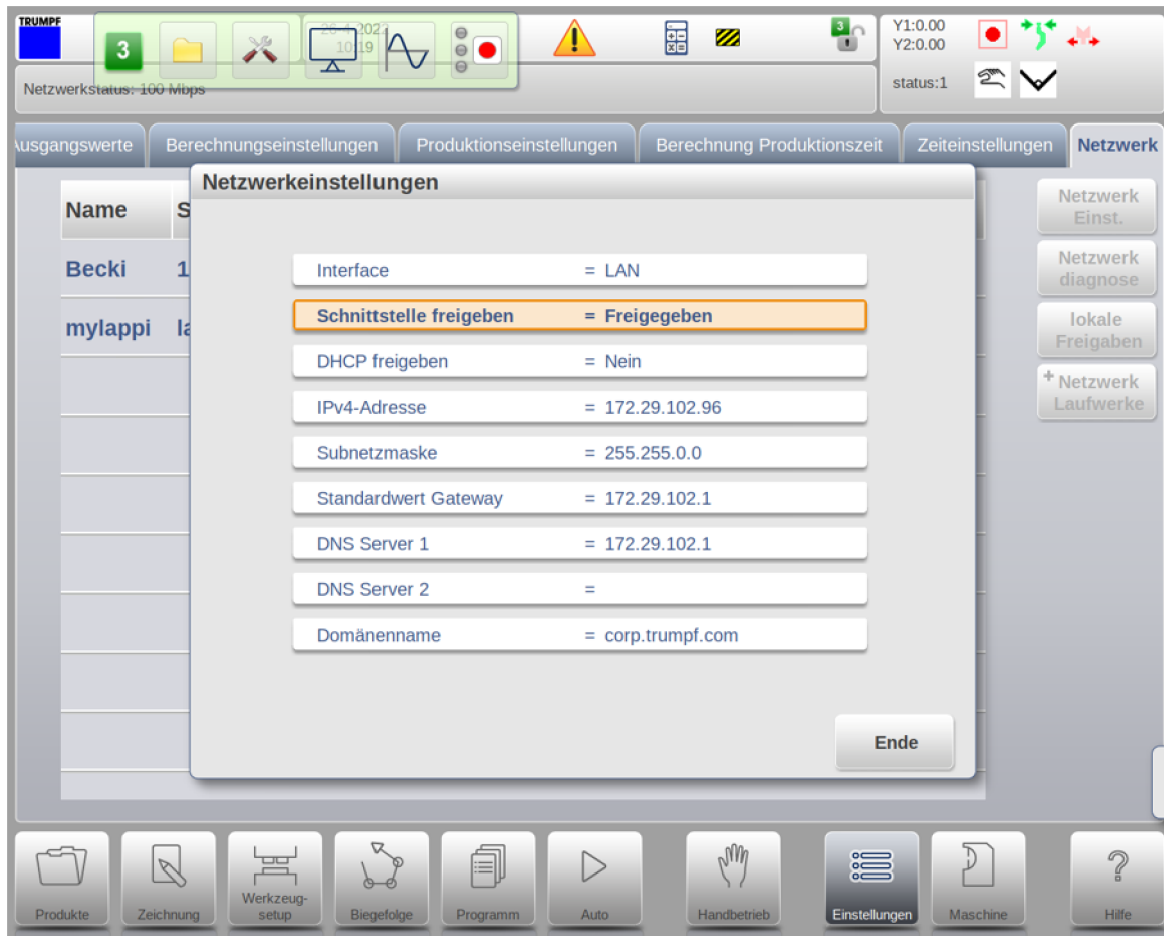

Network settings

Fig. 129823

Network access to shared folders

The DELEM control can access files of the customer network via SMB2 and SMB3. For this purpose, **customer-specific settings for network access must be entered**. When the controller successfully accesses a bending program server, the corresponding network drive status is set to "active".

This network drive with all its subfolders and files is then visible in the file manager under "Network".

If ACB laser is used, the remote support IPC must be available to access files in the customer network.

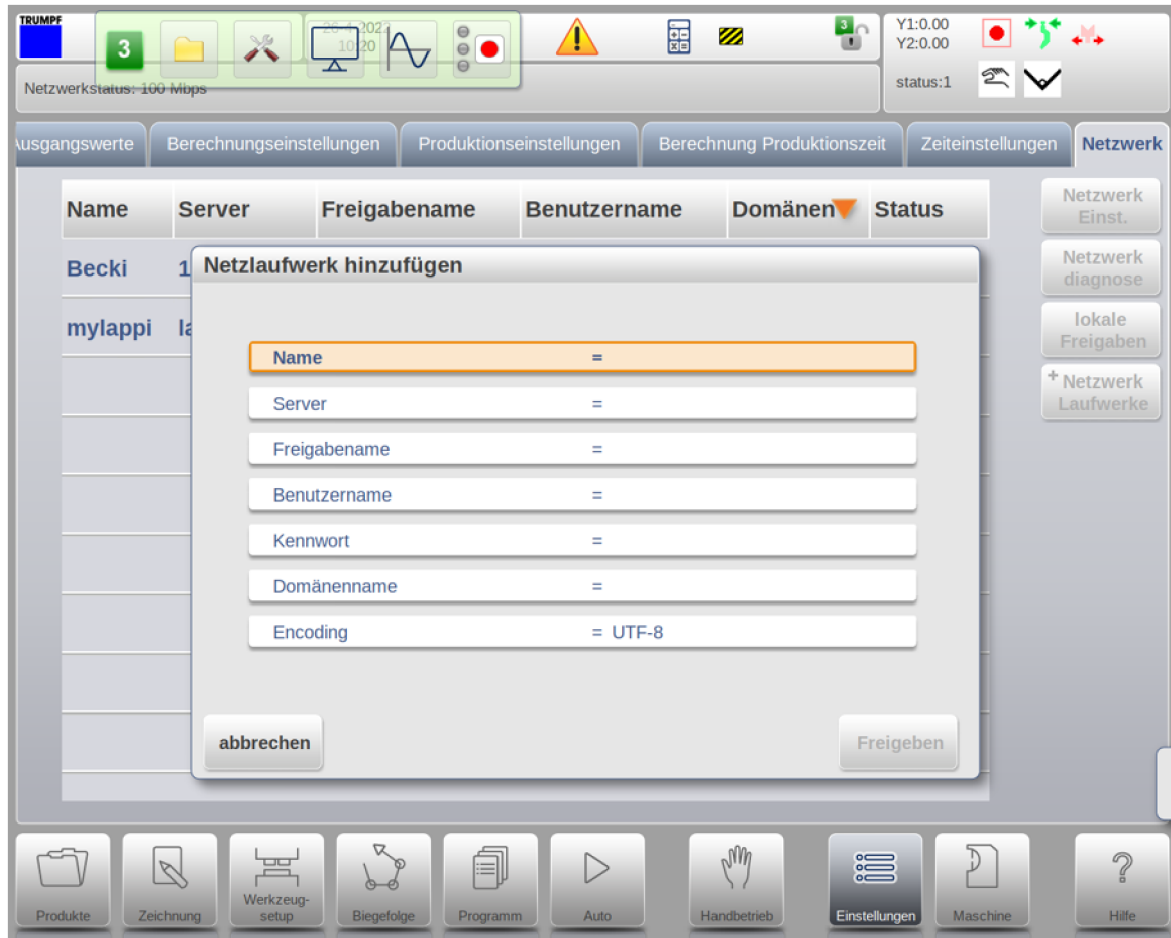

Adding the network drive to data exchange

Fig. 129824

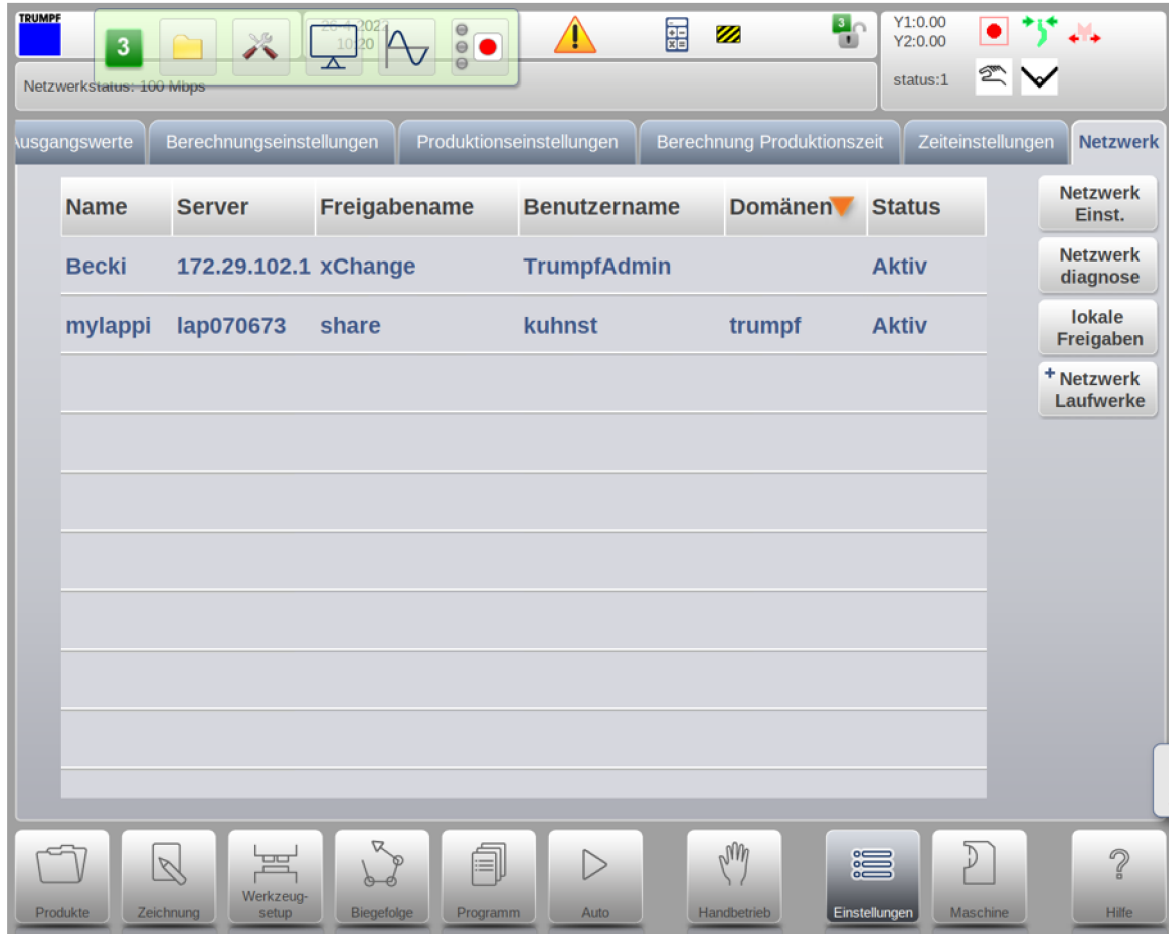

Active network drives with names Becki and mylappi

Fig. 129825

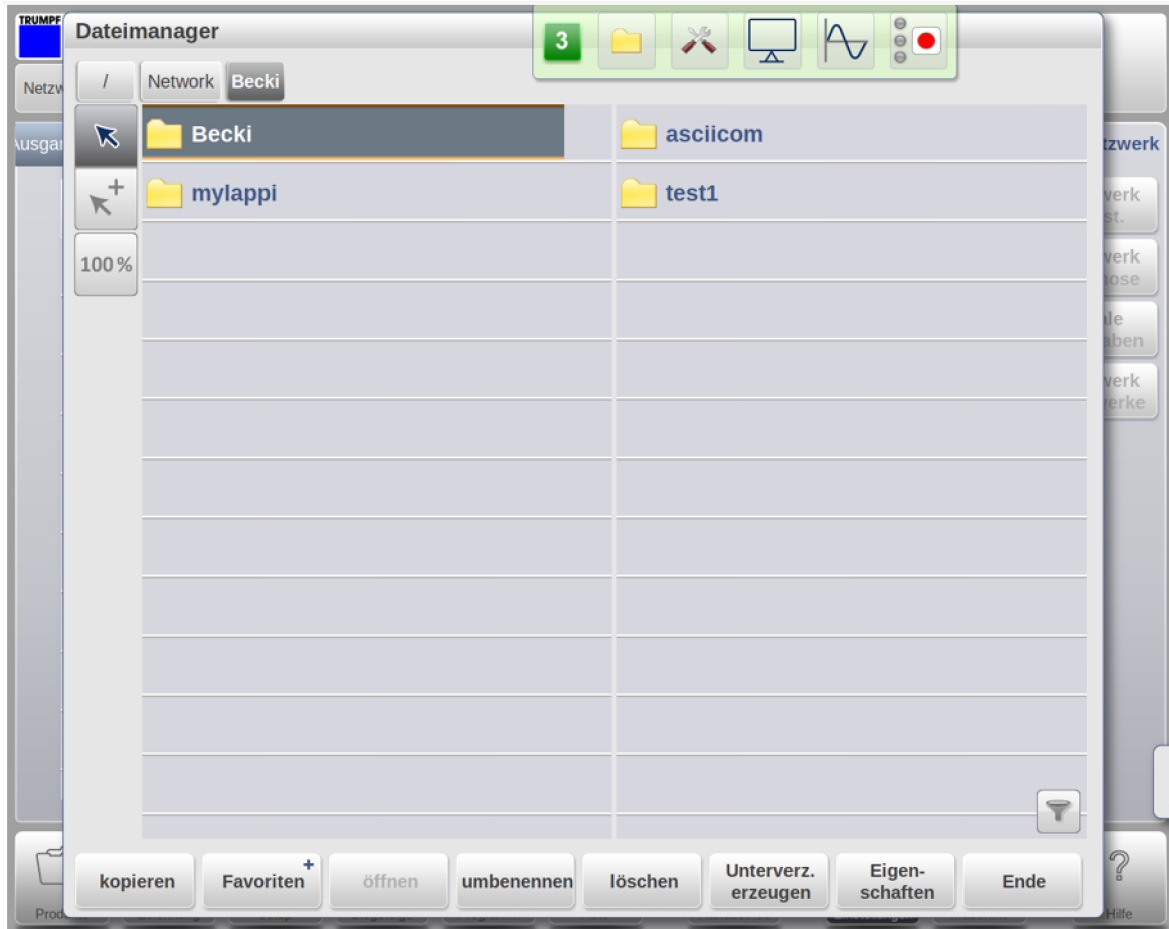

Network drive with subfolders and files

Fig. 129826

4. Operating materials

4.1 Hydraulic oil

Notes

- On delivery, the hydraulic oil tank is filled with the maximum quantity of hydraulic oil permitted.

Exceptions:

Due to the dangerous goods regulations, the machine must be delivered without filling in some countries. This exception regulation is referred to at the conclusion of the contract.

For air freight, the hydraulic oil will be delivered separately. If the machine is delivered with an unfilled hydraulic oil tank, Technical Service will provide an oil pump.

- Only filtered oil may be filled in the hydraulic oil tank. The filter used for this must have a filter fineness of 10 µm.

For initial filling, the following hydraulic oil is used:

- TruBend Fluid (mat. no. 2252991).

Notes

- Hydraulic oil from other manufacturers can also be used if it is certified as having equivalent properties (specification in accordance with DIN 51524-3).
- TRUMPF recommends the use of TruBend Fluid. When other hydraulic oils are used, this can lead to noise development or impairment in the running behavior.

Hydraulic oil volume

TruBend	Hydraulic oil volume
2100	110 l (29 gal)

Hydraulic oil volume: (X) = enlarged open height

Tab. 2-12

5. Preparation for commissioning

The customer must make the following arrangements before the machine is commissioned by the TRUMPF service engineer:

- Transport the machine to the installation site (see Chapter 6, Transport).
- Position the machine and drill holes for the anchor bolt (see Chapter 7, Installation).
- Position the adjustable legs provided for the purpose beneath the machine (see Chapter 8, Set-up).
- Assemble the support brackets provided (see Chapter 9, Support bracket).
- Connect the foot switch and network cable (see Chapter 10, Foot switch and network cable).
- Have the machine connected to the power supply by an electrician (see Chapter 11, Electrical connection).

The work steps for this are described in the following Chapters.

6. Transport

The arrangements and transport of the system from the truck to its final installation site need to be prepared and carried out.

Machine conveyance to customer's site by TRUMPF





In some countries the user can have TRUMPF transport the system from the truck to the final installation site, the so-called "Rigging". The transport route may not exceed the length contractually agreed to. The transport route must be flat, with no steps or ramps.



If the user has commissioned TRUMPF with the rigging of the machine, the user must only ensure that the transport route meets the requirements mentioned below. TRUMPF will deal with all the other points mentioned in the following, including auxiliary tools and means of transportation.

6.1 Preparing transport

Check the following before delivery:

- Is there sufficient space for transport to the installation site?
- Can the floor can be crossed with armored rollers, etc.?
- Are the gateway openings, header heights and cable rack heights sufficient?

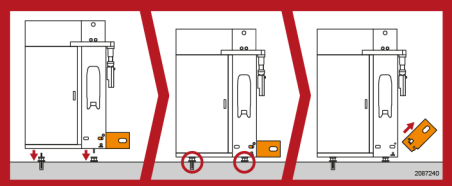
Safety-relevant signs on the machine	Description
	Risk of tilting
	Machine is top-heavy. Secure the machine from toppling over until it is anchored in the foundation.
	Secure machine on the truck during transport.
	Position of center of gravity.

Safety-relevant signs on the machine	Description
	<p>Only remove the transport securing device when the machine is anchored.</p>
	<p>Jacking point for hydraulic hoisting jack.</p>

Safety-relevant signs on the machine

Tab. 2-13

Transport dimensions

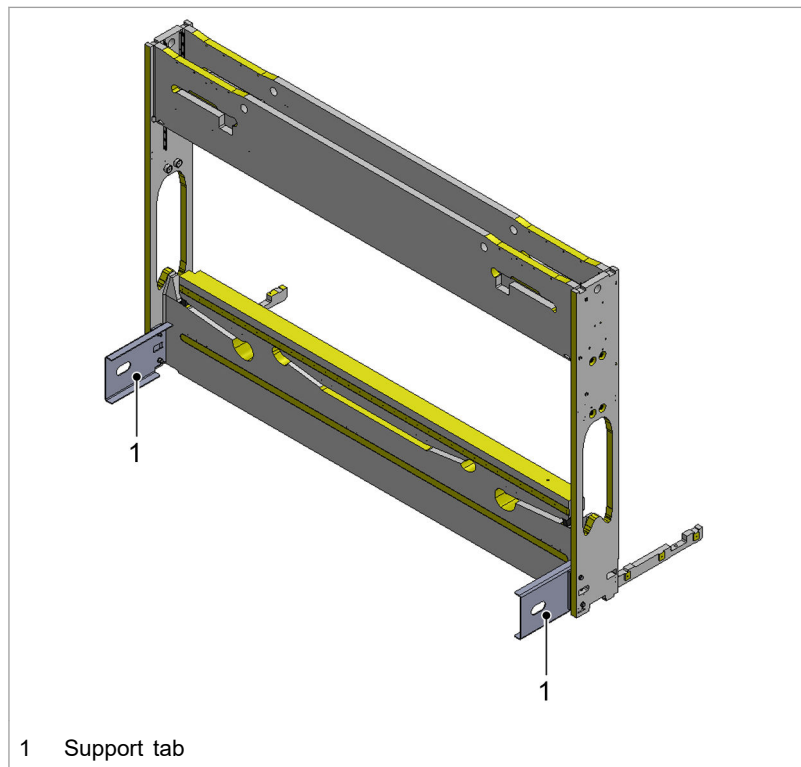

Fig. 78168

TruBend	2100
Weight	7500 kg (16534 lb)
Length	3607 mm (139 in)
Width (including support tab)	2094 mm (82 in)
Height	2370 mm (93.3 in)

Transport dimensions: (X) = enlarged open height

Tab. 2-14

6.2 Permitted auxiliary tools

Note

The carrying capacity of the authorized auxiliary equipment must be selected in such a way that the maximum load can be transported safely.

Authorized additional equipment	Carrying capacity
Crane truck for unloading the truck	According to the machine weight
Gantry crane for transporting the machine or Armored rollers: 1 steerable, 2 fixed Max. height of the armored roller: 140 mm	According to the machine weight or At least 10 t (22047 lb) each
At least two hydraulic hoisting jacks	At least 8 t (17637 lb) each
Hoisting iron with extension. Length: 1 m (3.28 ft)	–
When transporting with a crane: two type A shackles (DIN 82101)	According to the machine weight
Adjustable crane chain	According to the machine weight
Lifting belt	According to the machine weight

Permitted auxiliary tools

Tab. 2-15

Shackles When transporting the machine with a crane: use two type A shackles (DIN 82101):

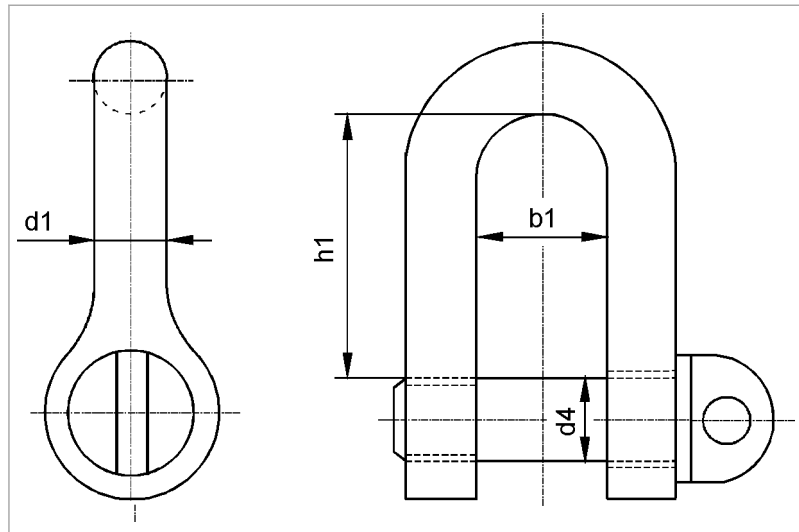

Type A shackle

Fig. 52814

TruBend	2100
Permissible loading	120 kN
Bolt diameter	2"
d1	47 mm (1.85 in)
d4	52 mm (2.05 in)
h1	158 mm (6.22 in)
b1	73 mm (2.87 in)

Shackle dimensions, form A

Tab. 2-16

6.3 Checking, unloading and transporting the machine

Checking delivery

1. Examine all components for any transport damage.
2. Record visible damage caused during transport on the cargo note and have the record countersigned by the truck driver.
3. Report any hidden transport damage to the insurance company and TRUMPF within six days.

Unloading and transporting the machine

Means, Tools, Materials

- For transport with armored rollers:
 - 4 wooden blocks 140 x 80 x 450 mm (included in the scope of delivery of the machine).
 - 4 screws (included in the scope of delivery of the machine).

Notes

- Place the support areas of the armored rollers exactly below the specified position.
- Move the machine carefully by hand. Do not use a forklift truck or other motorized tractors as there is a danger of tilting due to abrupt movements.
- Lift and lower the hydraulic hoisting jack extremely carefully and smoothly. Operate the machine with the hydraulic hoisting jack carefully and smoothly.
- Place the hydraulic hoisting jack on the marked jacking point:



- Do not transport the machine on a slope. Danger of tilting!
- Ensure that the contact surfaces of the hydraulic hoisting jack and armored rollers to the machine body are free of grease, oil and dirt.
- Ensure that all persons are clear of the danger zone when the machine is being transported, lifted and set down.
- Only ever at the side of the machine. Never stand in front of the machine. Danger of tilting!
- Bring the machine to the height of the armored rollers in stages and secure it with wooden blocks.
- Ensure that transport aids, transport devices, screws, etc. are in perfect condition.
- Only remove transport devices when the machine has been firmly anchored on the installation site.
- Remove bending tools before transport.

⚠ DANGER**Suspended load!**

Falling loads could lead to severe bodily injury or even death.

- Observe safety regulations for the handling of heavy loads.
- Never walk under a suspended load.
- Use tested and appropriately sized tackle and means of transportation.
- Employ qualified technicians to transport the machine.
- Carry out transport in accordance with the transport regulations.
- Only place the machine on firm, horizontal ground, even during intermediate storage and machine changeover.

⚠ DANGER**The machine is tilting forwards!****Risk of fatal injury!**

- There must be no one in the danger zone during transport.
- The machine may only be transported, temporarily stored and moved when transport securing devices are installed.
- The transport devices may only be removed once the machine is securely anchored.
- The machine may be operated only if it is anchored firmly in the foundation.

Observe the position of the center of gravity when transporting the machine:

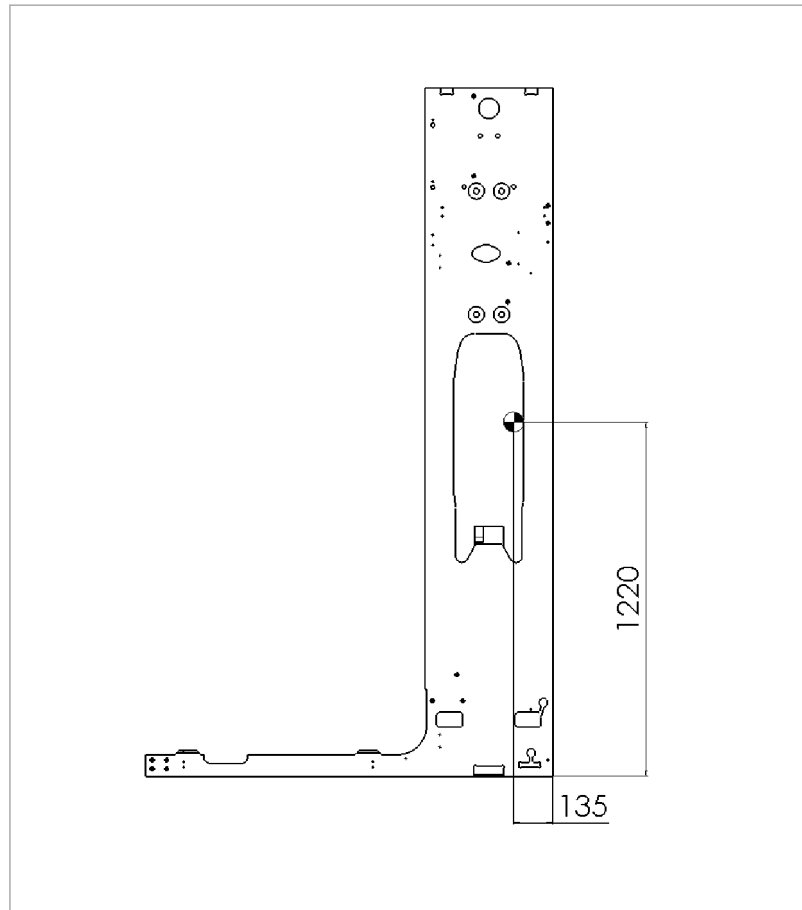

2100: Position of center of gravity

Fig. 129833

The following transport securing devices may only be removed when the machine is anchored in the foundation:

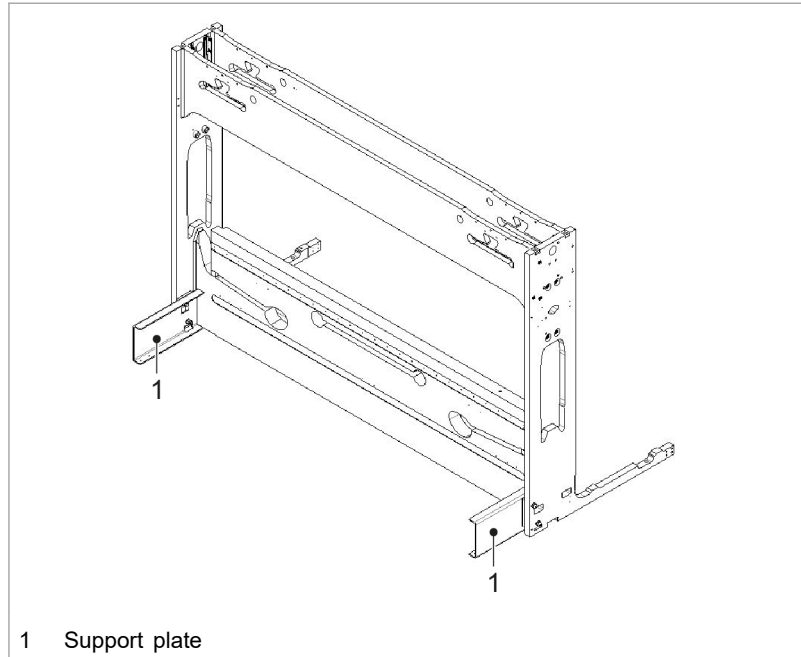
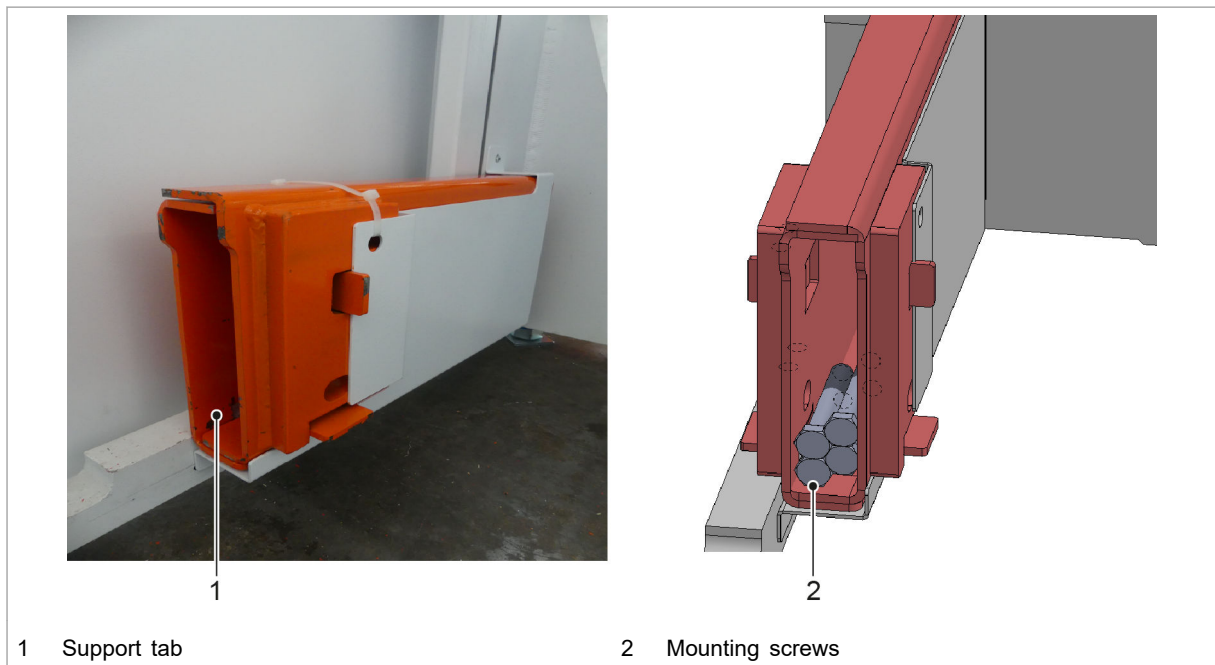

Fig. 102831

All transport securing devices must be stored in a safe place for future use. If the machine is moved or shifted at a later stage, the transport securing devices must be reinstalled.



Storing the transport securing devices

Fig. 116527

The machine can be lifted and transported using the suspension holes:

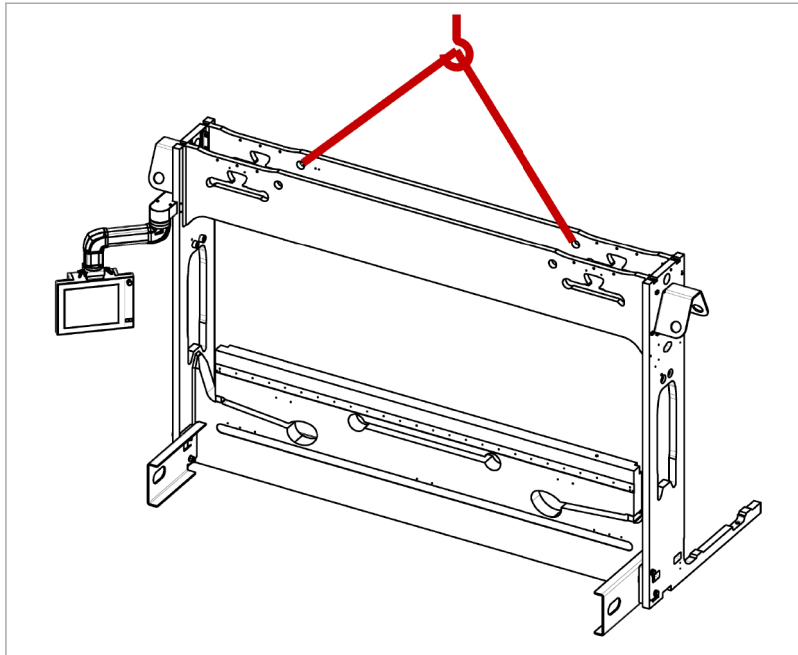

Transport using crane

Fig. 82048

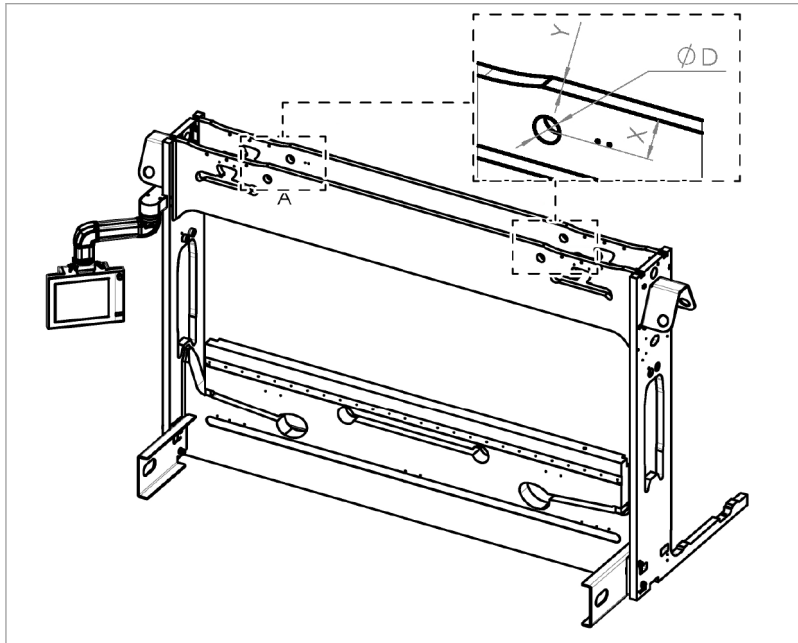

Suspension holes

Fig. 82049

TruBend	2100
Diameter D	55 mm (2.2 in)
Distance X to upper edge of machine	90 mm (3.6 in)
Thickness Y of the bridge plate	40 mm (1.6 in)

Dimensions of the suspension holes

Tab. 2-17

Unloading the machine

1. Remove machine packaging.
2. Secure the shackles to the suspension holes of the machine.
3. Unload the machine using a crane. Further transport with armored rollers: Position the machine on wooden blocks.
4. Transport the accompanying accessories box and any accessory parts that may be separately packaged directly from the truck to the installation site with a forklift truck.

Transporting the machine using an indoor crane

5. Transport the machine to the installation site using an indoor crane with sufficient carrying capacity.

Preparing the machine for further transport with armored rollers

After unloading, the machine is placed on wooden blocks. Alternatively, it can first be placed on the ground and then placed on wooden blocks.

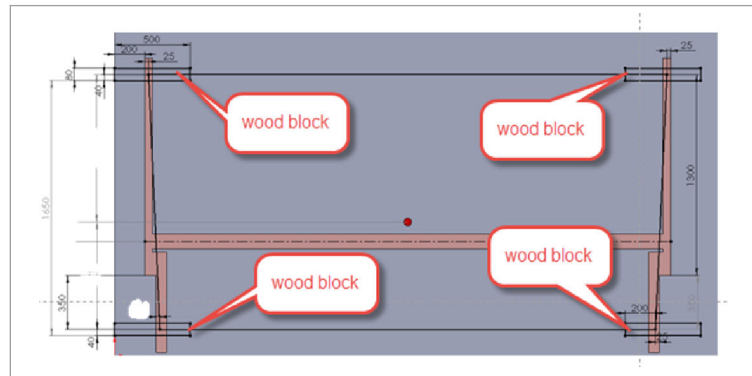

Positioning of the wooden blocks

Fig. 113758

6. Position wooden blocks.

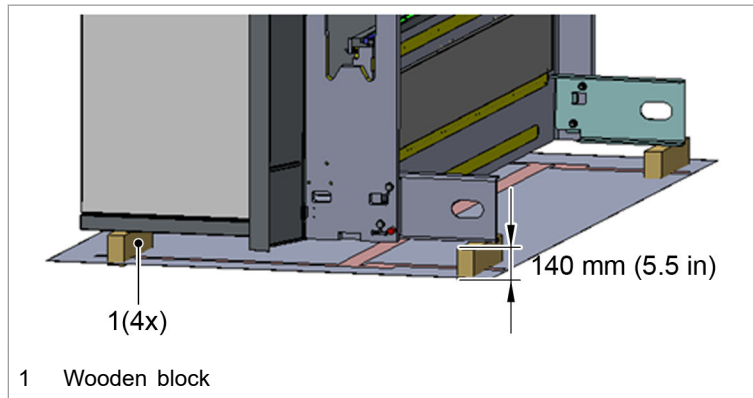

Position the machine on wooden blocks (included in the scope of delivery) Fig. 86615

7. Position the machine on wooden blocks.

or

- Place the machine directly on the floor and then on the armored rollers.

Due to a danger of tilting, **only** raise the machine using hydraulic hoisting jacks at the points marked (max. 150 mm (5.9 in)):

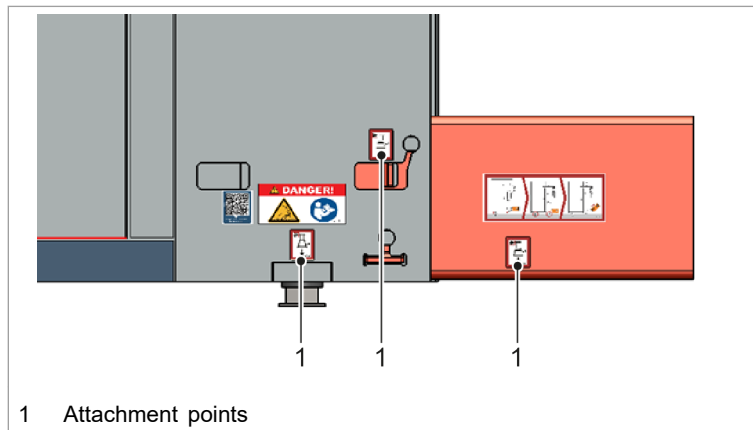

Attachment points for the hydraulic hoisting jack Fig. 116528

8. If the machine has been placed on the ground:

- Lift the machine and position on wooden blocks (see ["Lifting the machine from the ground without indoor crane and transporting with armored rollers"](#), pg. 2-43).
- Transport the machine to the installation site with armored rollers (see ["Transporting the machine using armored rollers"](#), pg. 2-35).

Transporting the machine using armored rollers

9. Open the side safety doors.

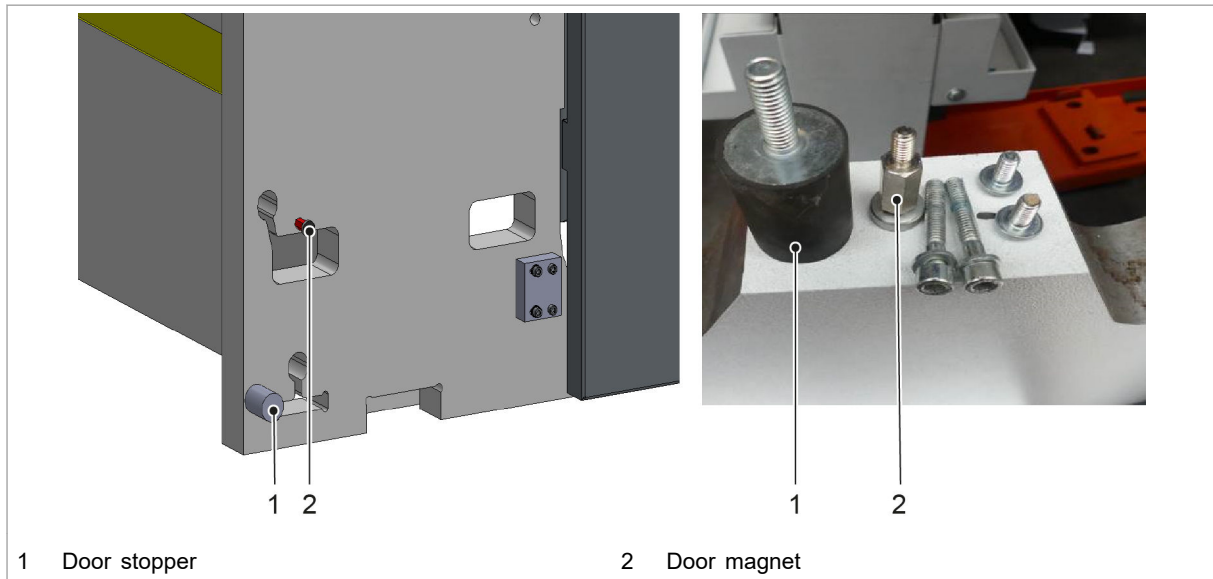
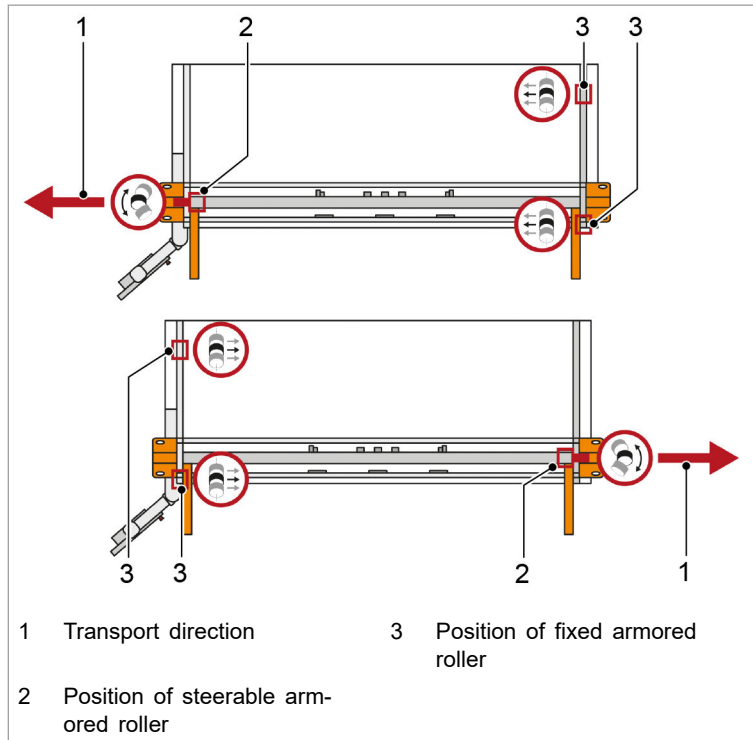

Fig. 116440

10. Remove the door stoppers and door magnets.

Notes

- The support areas of the armored rollers must be located centrally below the respective support points of the machine.
- Move the machine carefully and delicately and by hand only. Do not use a forklift truck or other motorized tractors as there is a risk of tilting due to abrupt acceleration.



Transport with armored rollers

Fig. 82050

11. Define transport direction.

Note

The following figures on the right show the procedure for transport direction as an example.

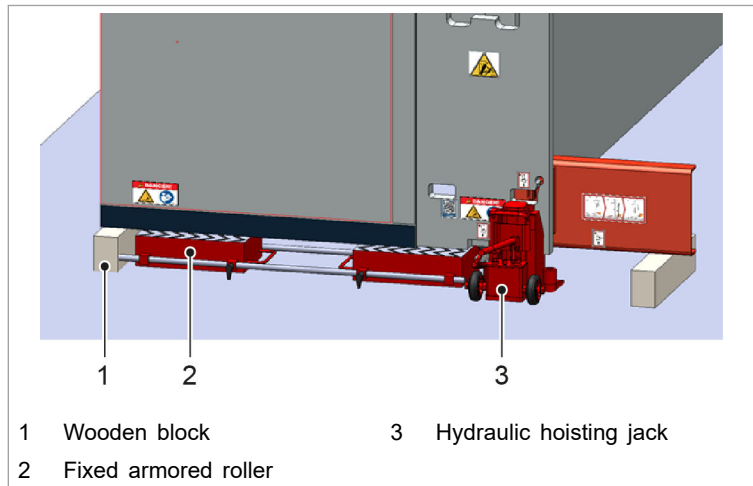

Positioning rigid armored rollers

Fig. 116530

12. Apply the hydraulic hoisting jacks and lift the machine.

13. Position rigid armored rollers.

14. Remove wooden blocks.

Note

Machine must only be lowered **slowly** by the hydraulic lifter!

- 15. Lower machine onto rigid armored rollers.
- 16. Secure the armored rollers against rolling away with the sheet metal strip.

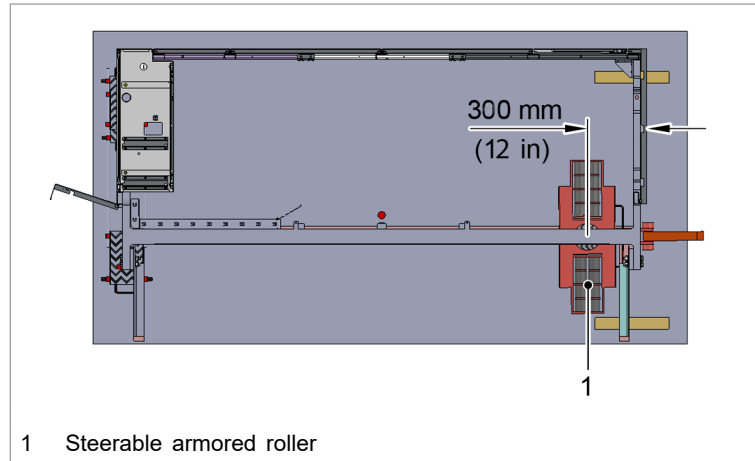

Positioning the steerable armored roller

Fig. 116531

- 17. Position the steerable armored roller.

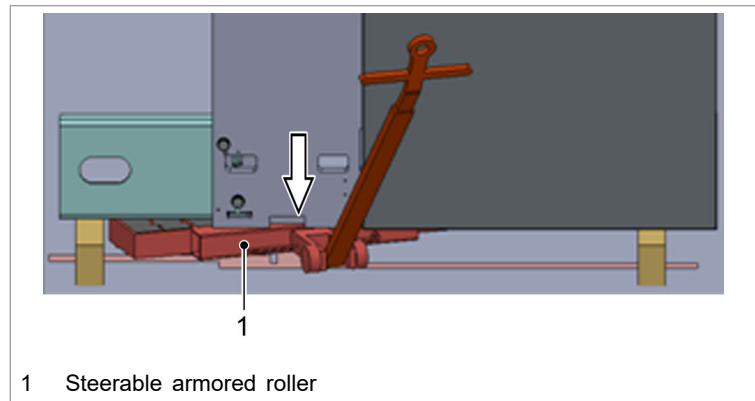

Alignment to recess on machine frame

Fig. 86617

- 18. Rotate the armored roller until the roller of the armored roller and the edge of the recess are flush on the machine frame (see arrow).

28. Safely store transport securing devices removed by Technical Service.

6.4 Relocating the machine

 **DANGER**

Suspended load!

Falling loads could lead to severe bodily injury or even death.

- Observe safety regulations for the handling of heavy loads.
- Never walk under a suspended load.
- Use tested and appropriately sized tackle and means of transportation.
- Employ qualified technicians to transport the machine.
- Carry out transport in accordance with the transport regulations.
- Only place the machine on firm, horizontal ground, even during intermediate storage and machine changeover.

 **DANGER**

The machine is tilting forwards!

Risk of fatal injury!

- There must be no one in the danger zone during transport.
- The machine may only be transported, temporarily stored and moved when transport securing devices are installed.
- The transport devices may only be removed once the machine is securely anchored.
- The machine may be operated only if it is anchored firmly in the foundation.

Mounting the transport securing devices

Means, Tools, Materials

- Transport securing devices
 - TruBend 2100 (mat. no. 2345378)
- Open-end wrench, size 13.
- Size 6 Allen key.
- Size 14 Allen key.
- Torque wrench with size 30 plug-in hex socket head.

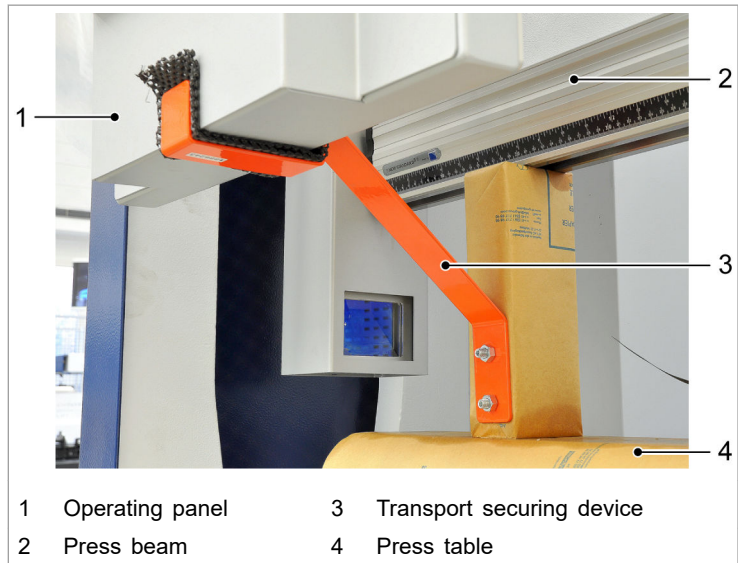

Transport securing device

Fig. 70376

1. Mount transport securing device.
Open-end wrench, size 13.

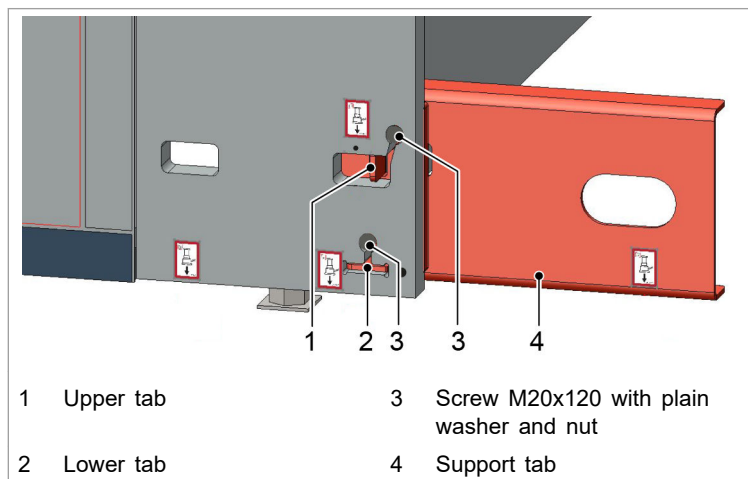
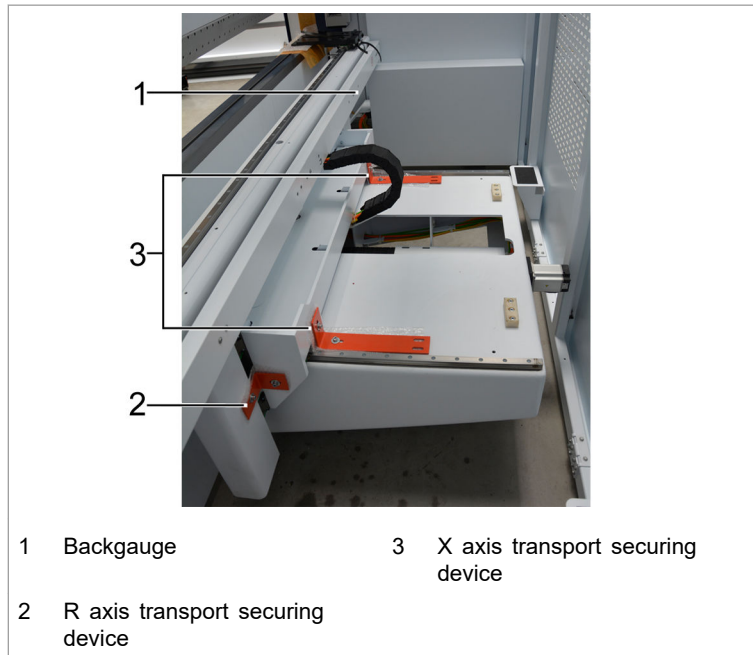

Fig. 86883

2. Apply support tab. When doing this, observe the vertical alignment to the machine and mounting position of the tabs.
3. Insert screws with plain washer and nut.
4. Tighten the screws to 390 Nm.
Torque wrench with size 30 plug-in hex socket head.



Transport securing devices for the backgauge

Fig. 72278

5. Mount the transport securing devices with 2 M8 screws each.
Size 6 Allen key.

Transporting the machine using an indoor crane

Conditions

- The machine was separated from the energy source by qualified personnel.
- The transport securing devices are installed.
- Anchoring has been detached.

▲ DANGER

Suspended load!

Falling loads could lead to severe bodily injury or even death.

- Observe safety regulations for the handling of heavy loads.
- Never walk under a suspended load.
- Use tested and appropriately sized tackle and means of transportation.
- Employ qualified technicians to transport the machine.
- Carry out transport in accordance with the transport regulations.
- Only place the machine on firm, horizontal ground, even during intermediate storage and machine changeover.

⚠ DANGER**The machine is tilting forwards!****Risk of fatal injury!**

- There must be no one in the danger zone during transport.
- The machine may only be transported, temporarily stored and moved when transport securing devices are installed.
- The transport devices may only be removed once the machine is securely anchored.
- The machine may be operated only if it is anchored firmly in the foundation.

- Procedure for indoor cranes: (see "Unloading and transporting the machine", pg. 2-29)

Lifting the machine from the ground without indoor crane and transporting with armored rollers

Required additional equipment for transport with armored rollers

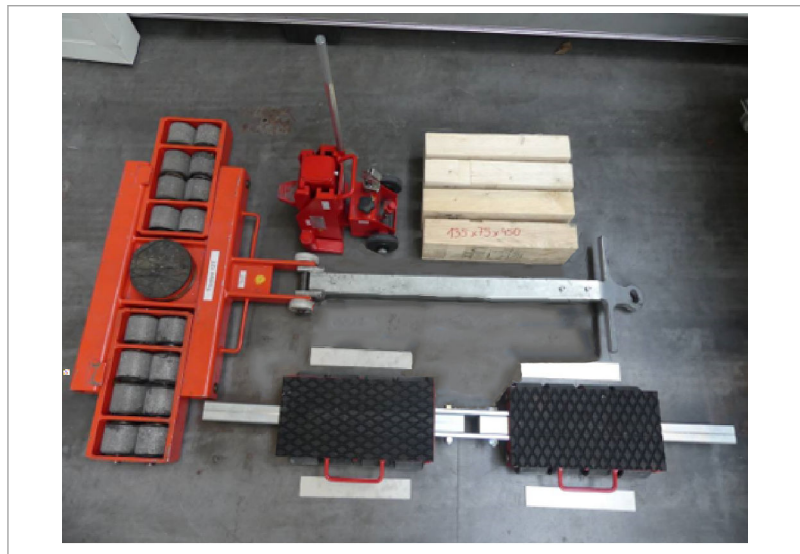

Required additional equipment for transport with armored rollers

Fig. 116510

Condition

- The machine has been disconnected from the energy source by qualified personnel.

Means, Tools, Materials

- Transport device (mat. no. 2636798).
- 4 high strength wooden blocks, 140 mm x 80 mm x 450 mm (5.5" x 3.1" x 17.7").

- Hydraulic hoisting jack with 8 t carrying capacity.
- 2 armored rollers, rigid, with 8 t (17637 lbs) carrying capacity.
 - Maximum height of the armored roller: 140 mm (5.6").
- 1 armored roller, steerable, with 8 t (17637 lbs) carrying capacity.
 - Maximum height of the armored roller: 140 mm (5.6").
 - **All three armored rollers must be the same height.**
- Angle grinder.
- Impact drill, drill bit Ø16 mm (0.62").
- 4 sheets, 5 mm x 150 mm x 400 mm (0.2" x 6" x 16").
- Torque wrench 390 Nm + socket.
- Standard tool set.

Notes

- Place the support areas of the armored rollers exactly below the specified position.
- Move the machine carefully by hand. Do not use a forklift truck or other motorized tractors as there is a danger of tilting due to abrupt movements.
- Lift and lower the hydraulic hoisting jack extremely carefully and smoothly. Operate the machine with the hydraulic hoisting jack carefully and smoothly.
- Place the hydraulic hoisting jack on the marked jacking point:



- Do not transport the machine on a slope. Danger of tilting!
- Ensure that the contact surfaces of the hydraulic hoisting jack and armored rollers to the machine body are free of grease, oil and dirt.
- Ensure that all persons are clear of the danger zone when the machine is being transported, lifted and set down.
- Only ever at the side of the machine. Never stand in front of the machine. Danger of tilting!
- Bring the machine to the height of the armored rollers in stages and secure it with wooden blocks.
- Ensure that transport aids, transport devices, screws, etc. are in perfect condition.
- Only remove transport devices when the machine has been firmly anchored on the installation site.
- Remove bending tools before transport.

⚠ DANGER**Suspended load!**

Falling loads could lead to severe bodily injury or even death.

- Observe safety regulations for the handling of heavy loads.
- Never walk under a suspended load.
- Use tested and appropriately sized tackle and means of transportation.
- Employ qualified technicians to transport the machine.
- Carry out transport in accordance with the transport regulations.
- Only place the machine on firm, horizontal ground, even during intermediate storage and machine changeover.

⚠ DANGER**The machine tilts forward!**

- All persons must be clear of the danger zone during machine transport.
- The machine may only be transported, temporarily stored and moved when transport devices are installed.
- The following transport devices may only be removed when the machine has been firmly anchored to the foundation.

Defining the transport direction**Note**

The following figures on the right show the procedure for transport direction as an example.

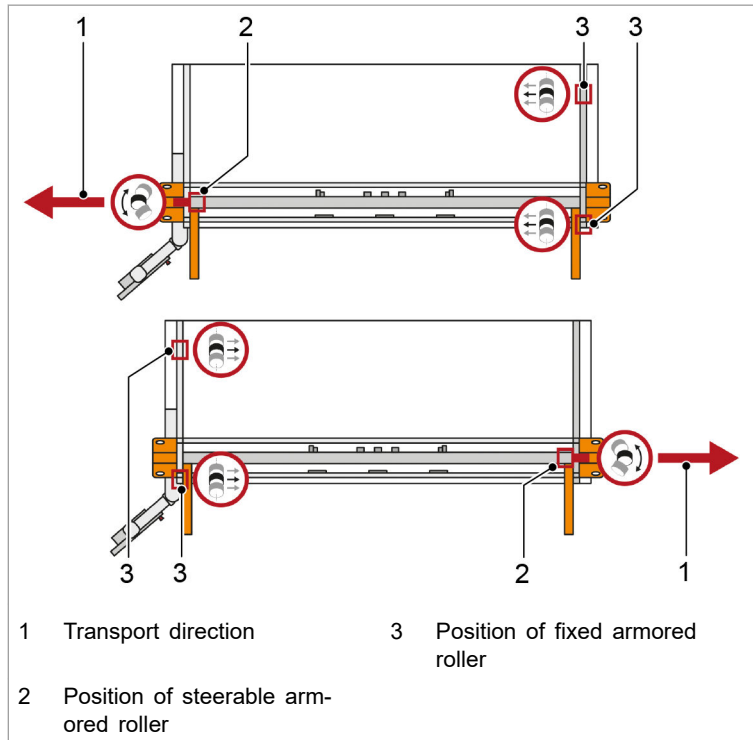

Transport with armored rollers

Fig. 82050

1. Define transport direction.

Preparing the machine for transport

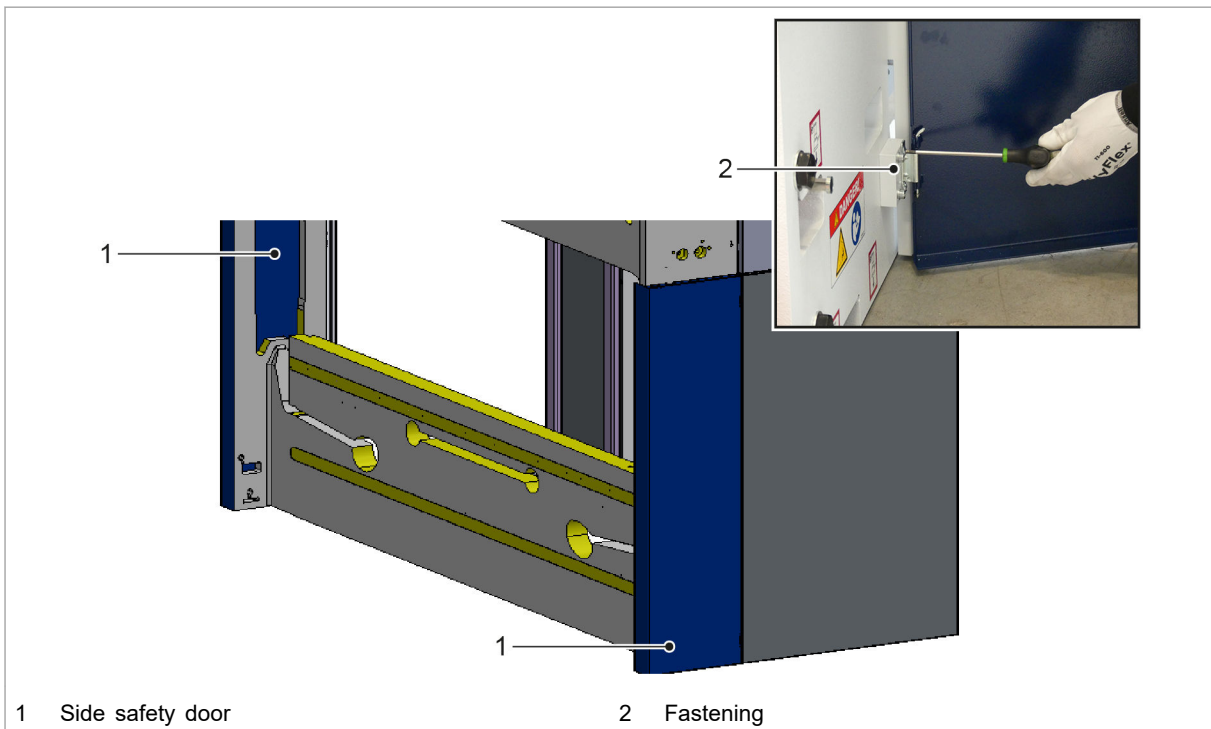

Attaching the lateral safety doors

Fig. 116286

2. Remove the lateral safety doors on the left and right as well as the attachment parts.

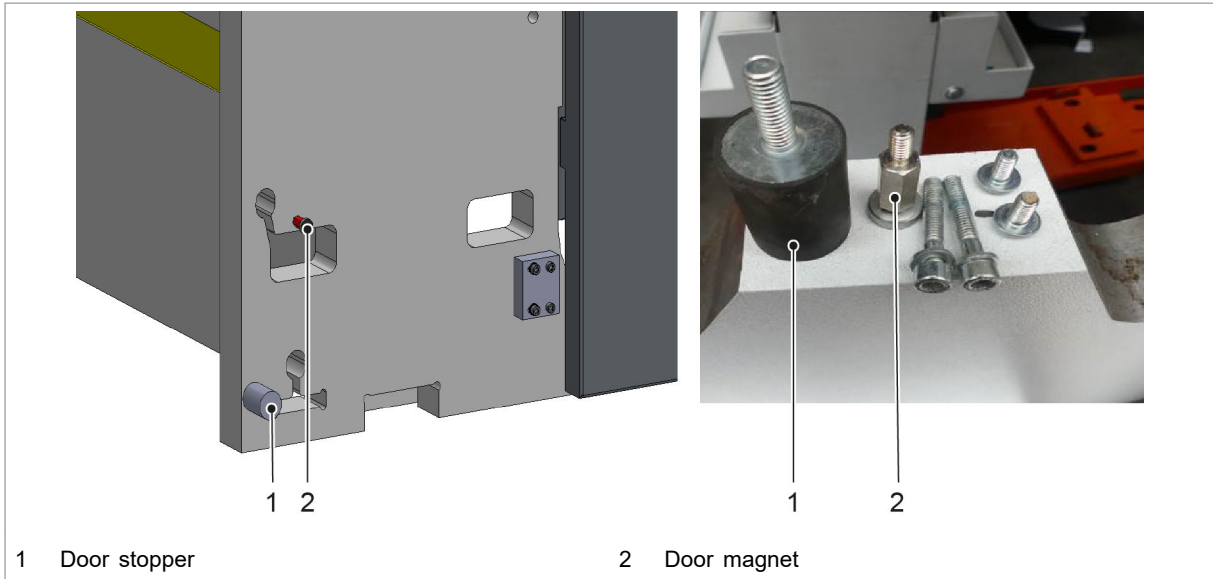
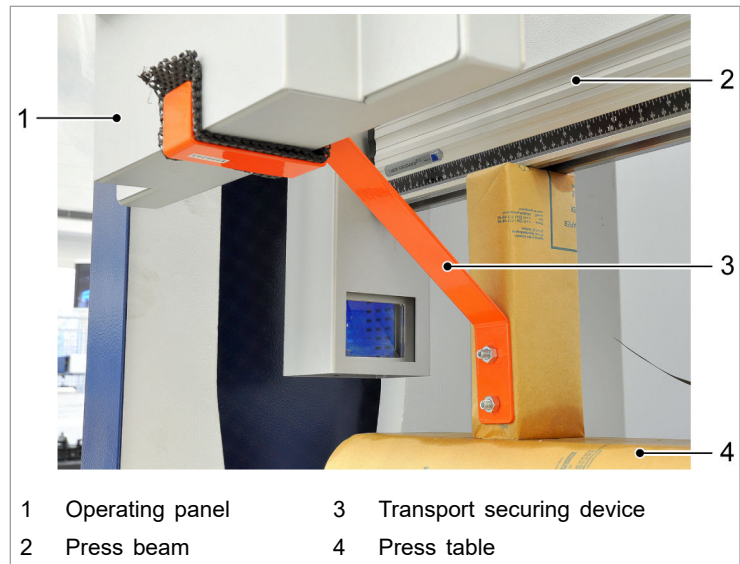

Fig. 116440

3. Remove door stoppers and door magnets on the left and right.



Transport securing device

Fig. 70376

4. Mount transport securing device of the operating panel.

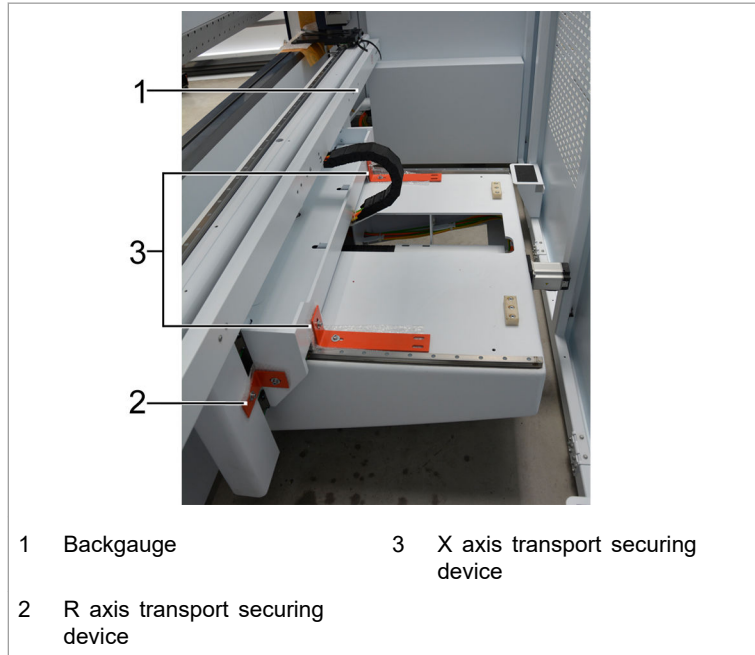

Transport securing devices for the backgauge Fig. 72278

5. Mount the transport securing device of the back gauge.



Cable tray Fig. 116441

6. If relocating an already anchored machine:
Remove the small cable tray on the left inside the machine (next to the electrical cabinet).
To do this, undo two M6x12 screws using an Allen key AF 4.

Remove the support tabs The following work is only to be performed if relocating an already anchored machine.

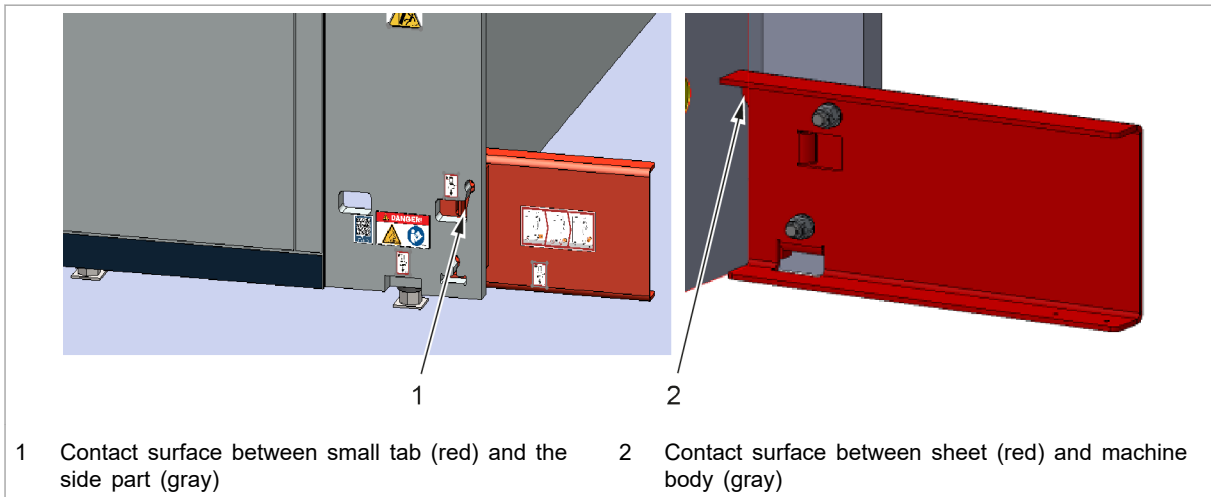

Form-locking connections

Fig. 116533

7. Mount the support tabs on left and right of the machine frame in a form-locking manner.

Ensure form locking!

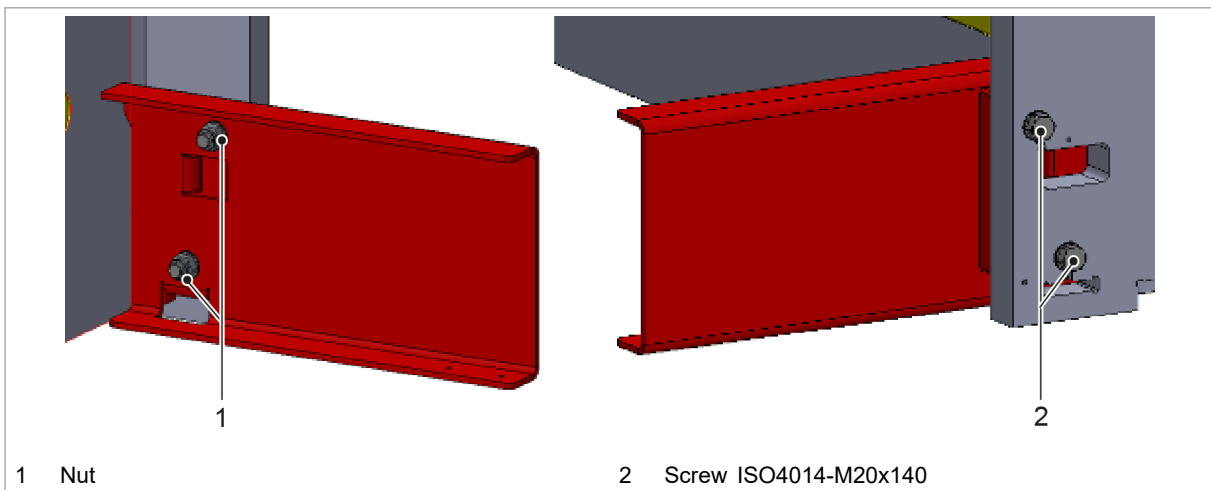

Position of screws and nuts

Fig. 116534

8. Tighten 4 ISO4014-M20x140 screws with a tightening torque of 390 Nm.

Loosen the anchoring of the machine

The following work is only to be performed if relocating an already anchored machine.

Note

Only loosen the anchoring on the left and right after both support tabs have been mounted.



Loosen the anchoring of the machine

Fig. 116447

9. Loosen the M16 nut on the anchoring and remove it with the corresponding plain washer.

Positioning the rigid armored rollers

10. Position the hydraulic hoisting jack in the opening in the left side part of the machine and lift the machine.

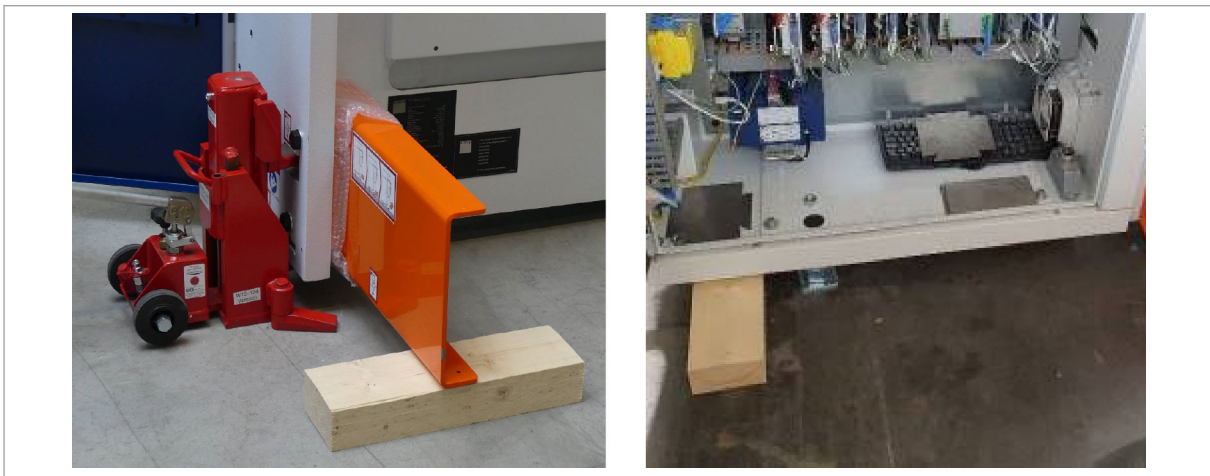

Lowering the left side of the machine to 80 mm

Fig. 116396

11. Place wooden blocks underneath on the 140 mm edge and lower the machine.
12. Position the hydraulic hoisting jack in the opening in the right side part of the machine and lift the machine.



Lowering the right side of the machine to 80 mm

Fig. 116535

13. Place wooden blocks underneath on the 140 mm edge and lower the machine.
14. Set the lifting bracket of the hydraulic hoisting jack one level higher.
15. Lift right side of the machine.



Lowering the right side of the machine to 140 mm

Fig. 116536

16. Turn the wooden blocks to the 80 mm edge and lower the machine.



Severing the drop-in anchor

Fig. 116454

17. If relocating an already anchored machine:
Sever the upper part of the drop-in anchor on the left, remove the adjustable leg, cut off the lower part of the drop-in anchor.

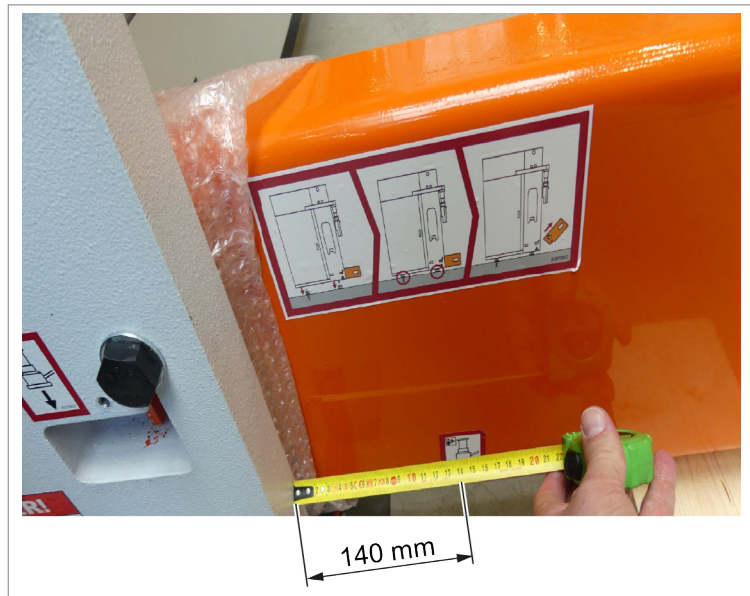

Position of the hydraulic hoisting jack on the support tab Fig. 116287

18. Change the position of the hydraulic hoisting jack (approx. 140 mm from the front side of the machine) and lift the machine.



Position of the rigid armored rollers

Fig. 116538

19. Position the rigid armored rollers with connecting bar under the machine.
20. Remove wooden blocks, lower the machine onto armored rollers.



1 Position of the rigid armored rollers

Position of rigid armored roller in relation to machine frame

Fig. 116462

21. Align armored rollers so that their front side is almost flush with the side column of the machine frame.

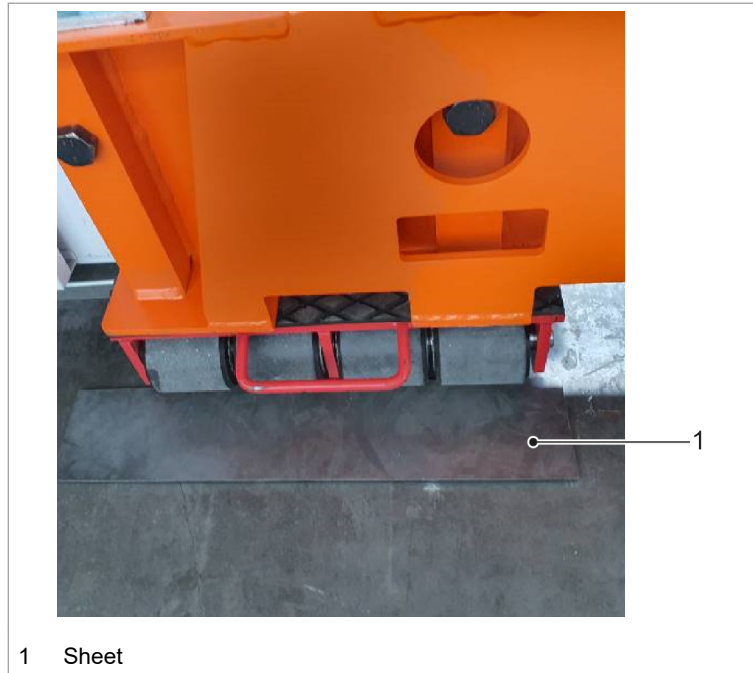

Securing protective plate against moving

Fig. 116288

22. Secure the left side of the machine from moving by using sheets.

**Position the steerable
armored rollers**



Severing the drop-in anchor

Fig. 116454

23. If relocating an already anchored machine:
Sever the upper part of the drop-in anchor on the right,
remove the adjustable leg, cut off the lower part of the drop-
in anchor.



Lowering the set screws

Fig. 116466

24. Completely countersink the set screws on the front right side of the machine.

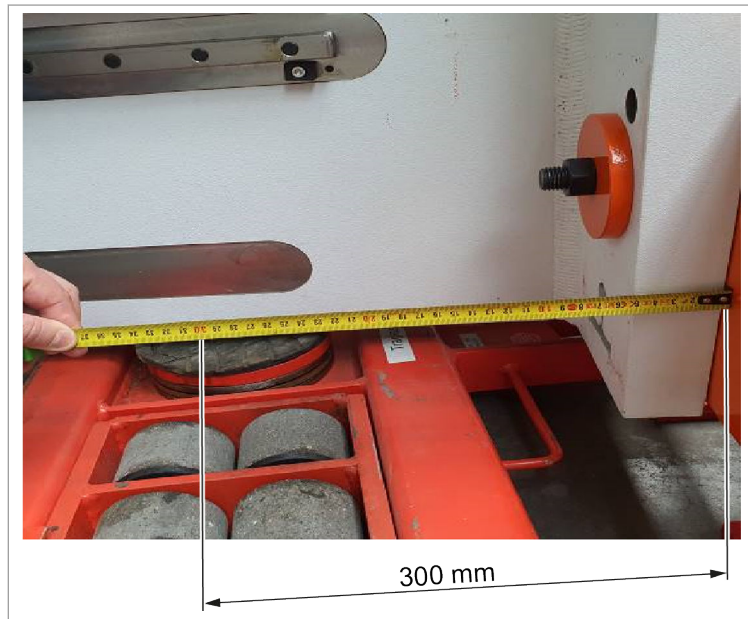

Position of the steerable armored roller

Fig. 116289

25. Centrally position the steerable armored roller approx. 300 mm under the machine table.



Position of the hydraulic hoisting jack

Fig. 116395

26. Position the hydraulic hoisting jack on the right side of the machine, lift the machine.
27. Remove wooden blocks, lower the machine onto armored roller, remove hydraulic hoist jack.

Machine is ready to be transported to the right.



Fig. 116540

Re-anchoring the machine to the installation site

28. Level and align the machine (see Service manual).

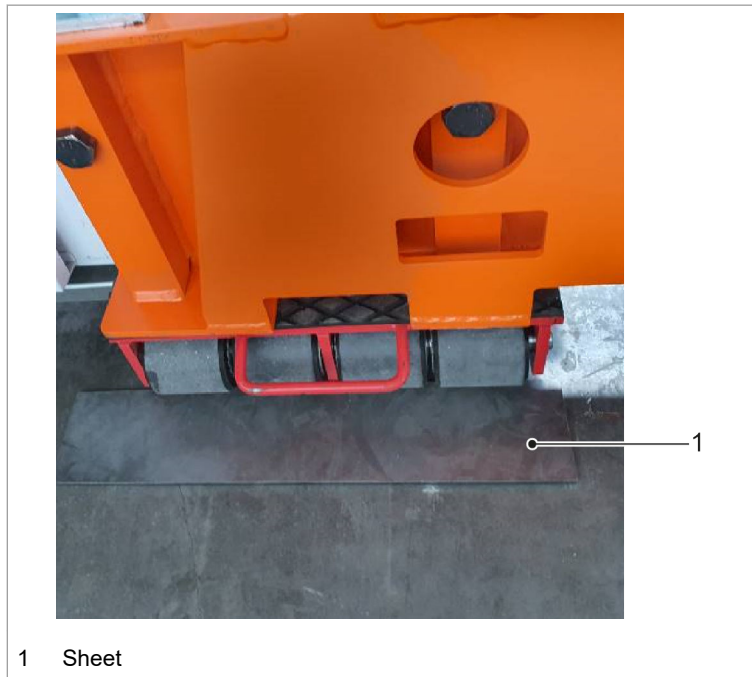

1 Sheet

Securing protective plate against moving

Fig. 116288

29. Secure the left side of the machine from moving by using sheets.
30. Position the hydraulic hoisting jack on the right, lift the machine.

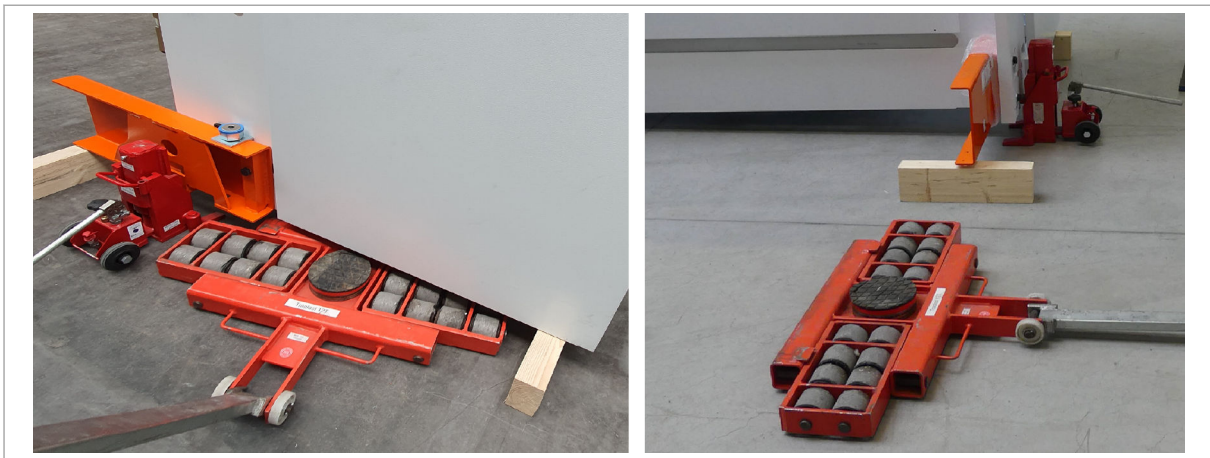

Removing steerable armored rollers

Fig. 116290

31. Place wooden blocks underneath on the 80 mm edge, lower the machine and remove the steerable armored rollers.

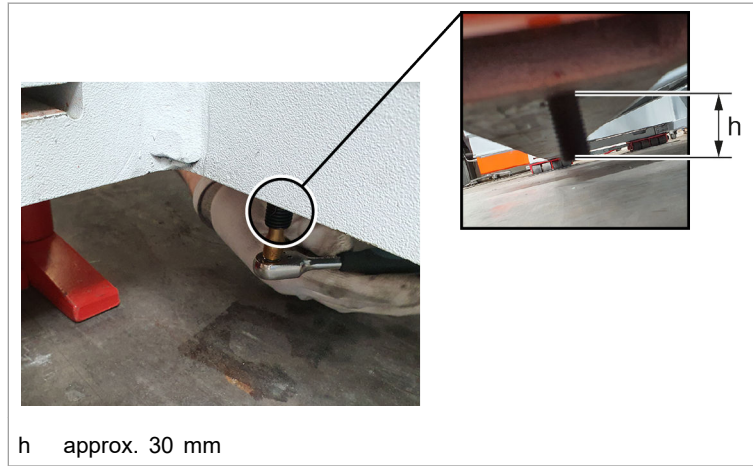

Unscrewing the set screws

Fig. 116291

32. Unscrew the set screws on the front left side of the machine to approx. 30 mm.



Fig. 116473

33. Set the adjustable leg to a height of approx. 50 mm and position it under the set screw.
34. Lift the machine.



Lowering the machine to 80 mm

Fig. 116543

35. Turn the wooden blocks to the 140 mm edge and lower the machine.



Aligning adjustable legs for drop-in anchors

Fig. 116475

36. At the rear of the machine, set the adjustable legs to a height of approx. 50 mm and align for drop-in anchors.



Position of the hydraulic hoisting jack on the support tab Fig. 116287

37. Position the hydraulic hoisting jack on the left side of the machine (approx. 140 mm from the front side of the machine) and lift the machine slightly.
38. Place wooden blocks underneath on the 80 mm edge.
39. Remove the lock washers.



Removing rigid armored rollers

Fig. 116545

40. Remove the rigid armored rollers.
41. Lower the machine.

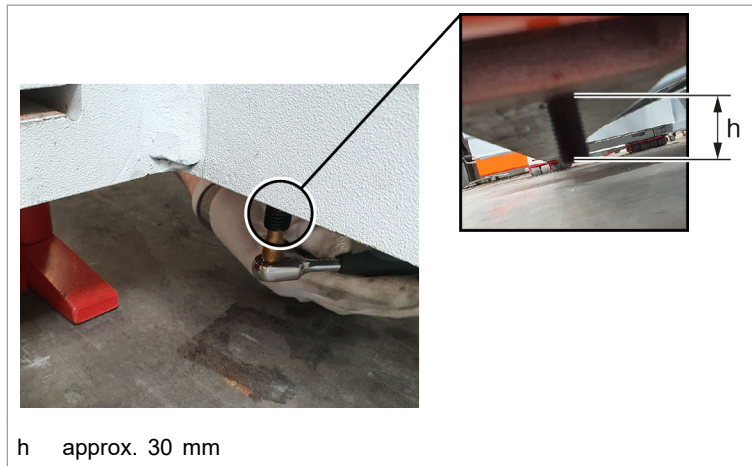

h approx. 30 mm

Unscrewing the set screws

Fig. 116291

42. Unscrew the set screws on the front left side of the machine to approx. 30 mm.

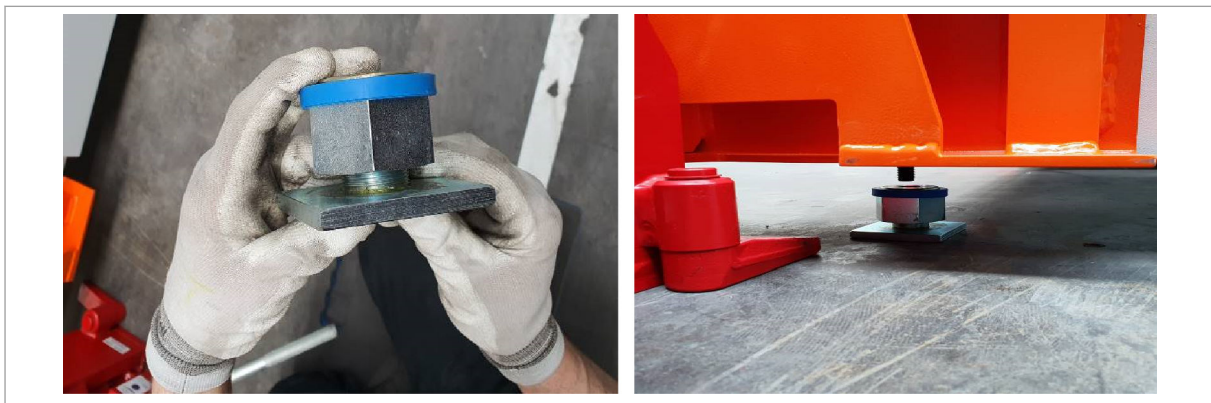

Setting the adjustable legs

Fig. 116473

43. Set the adjustable leg to a height of approx. 50 mm and position it under the set screw.

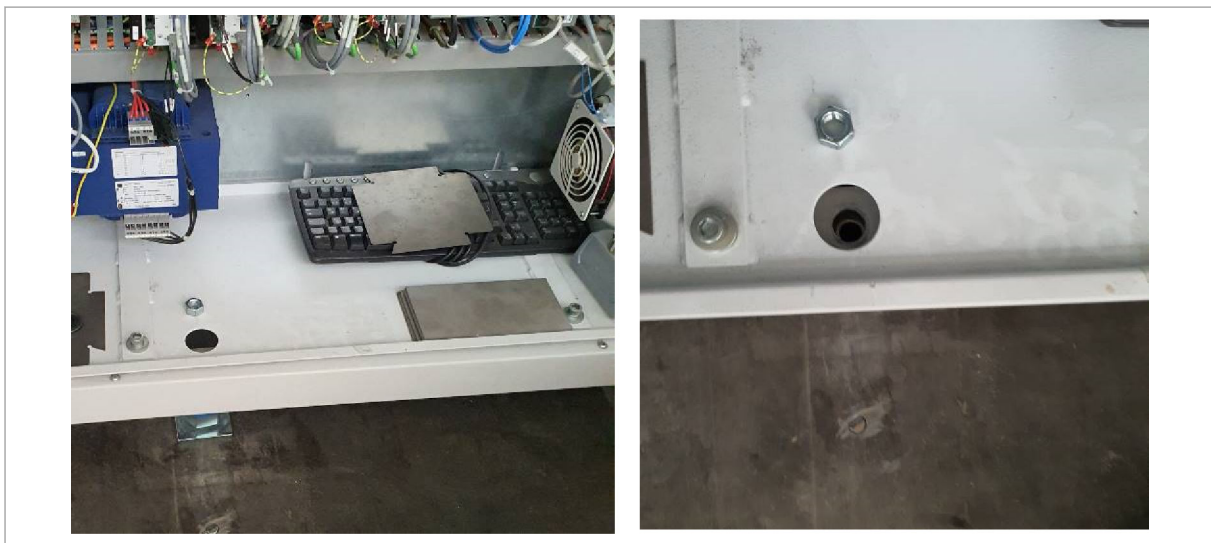

Aligning the rear adjustable legs

Fig. 116480

44. At the rear of the machine, align the adjustable legs with the machine body.
45. Position the hydraulic hoisting jack under the right support tab and lift the machine.



Lowering the left side of the machine to 80 mm

Fig. 116546

46. Turn the wooden blocks to the 140 mm edge and lower the machine.



Lowering the machine onto the adjustable legs

Fig. 116547

47. Lift the right side of the machine, remove wooden blocks and lower the machine onto the adjustable legs.



Aligning the adjustable legs for drop-in anchors

Fig. 116481

48. Ensure that the adjustable legs on the rear side of the machine are aligned to the positions of the drop-in anchors.
49. Drill holes on both sides according to the installation conditions.
 - Bore hole diameter 16 mm.
 - Drilling depth 85 mm.
50. Drive in drop-in anchor.

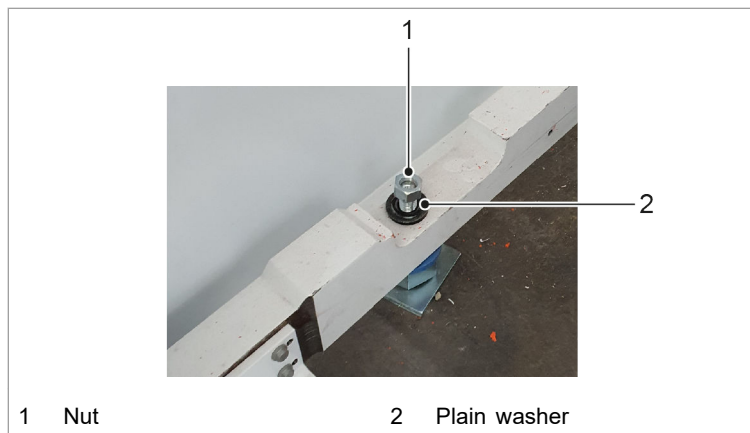

1 Nut

2 Plain washer

Screwing nuts onto drop-in anchors

Fig. 116470

51. Screw two M16 nuts with plain washers to the rear drop-in anchors.

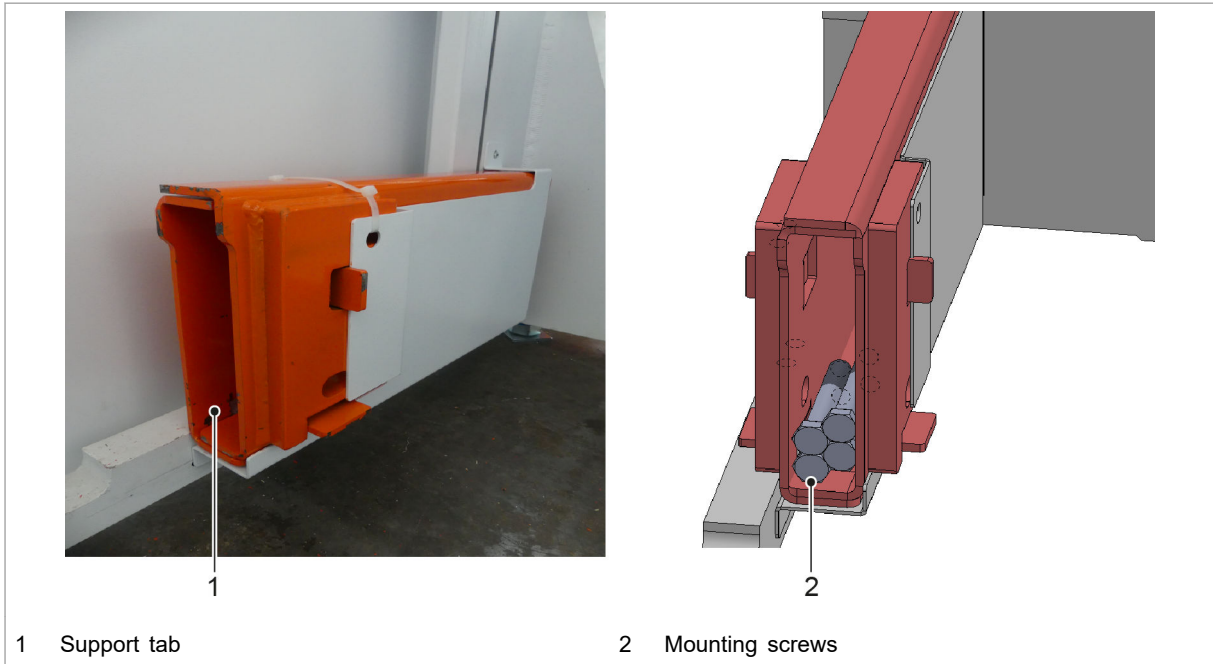

Storing the transport securing devices

Fig. 116527

52. Remove support tabs on both sides according to the installation conditions and store them safely together with the installation material in the designated place near the machine.
 - Fasten mounting materials such as screws, washers and nuts in a plastic bag with cable ties to existing openings on support tabs.



Cable tray

Fig. 116441

53. Reattach the cable tray.

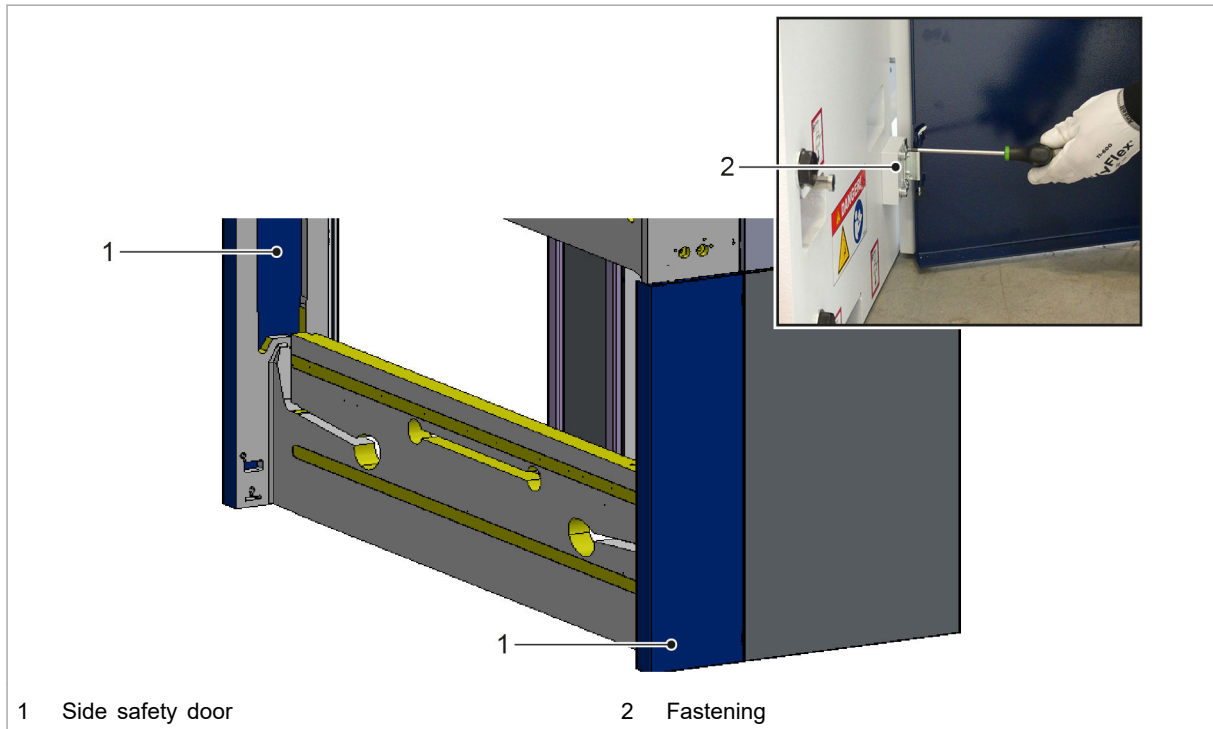

1 Side safety door

2 Fastening

Attaching the lateral safety doors

Fig. 116286

54. Reattach lateral safety doors on the left and right as well as the attachment parts.

Measures at the installation site

- 55. Have Technical Service anchor the machine in the ground.
- 56. Ensure that both door stoppers and door magnets are installed.
- 57. Safely store transport securing devices removed by Technical Service.

7. Installation

7.1 Positioning the machine and drilling holes

Note

The adjustable legs are set up later at the installation points following drilling.

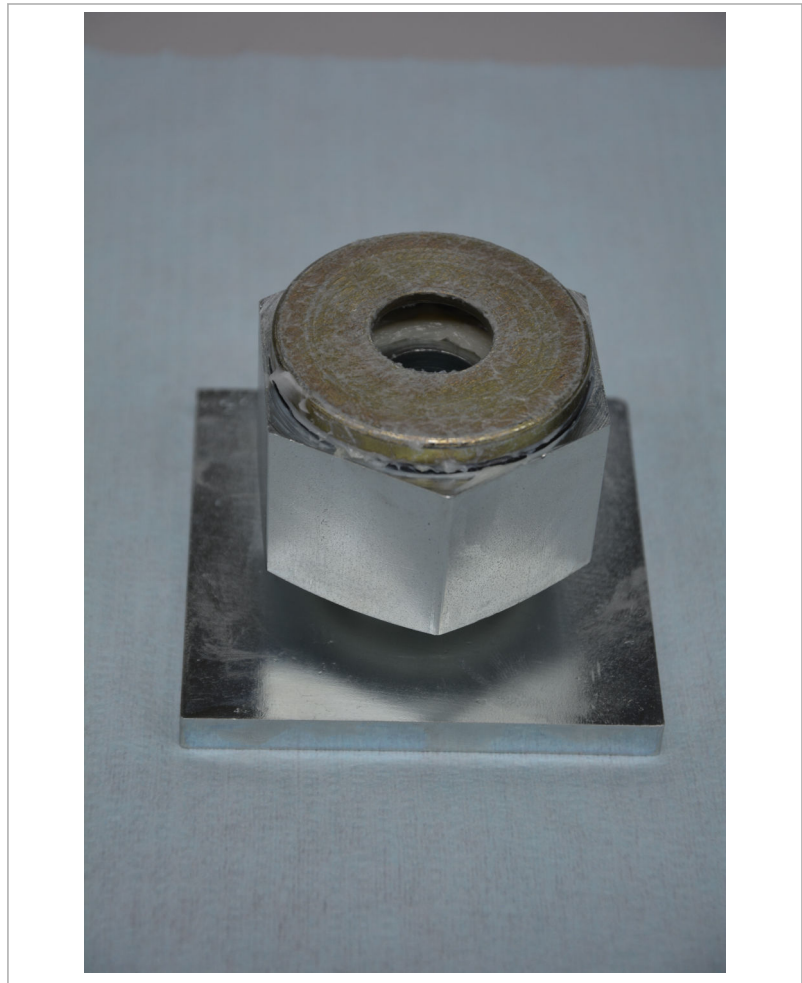

Fig. 72275

1. Using an indoor crane or forklift truck, position the machine at the installation site in accordance with the installation plan and align it.

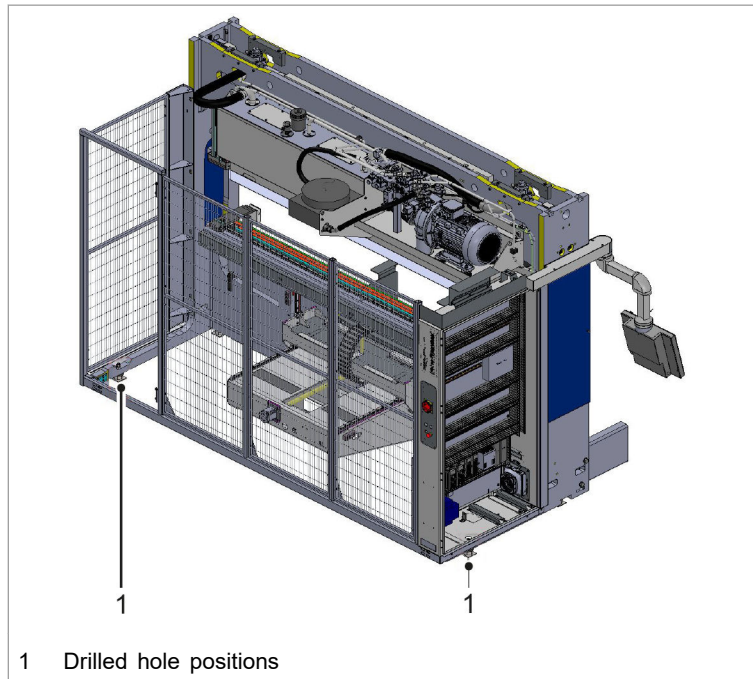

Fig. 102833

2. Open the electrical cabinet door and service door to access the drilled holes.

Note

The machine is bolted to the factory floor only at the rear, once on the left and once on the right.

Drill holes are drilled through the machine.

The holes must be drilled vertically and accurately.

The adjustable legs must stay free from dust to prevent the thread 'rubbing'. This is why they are only positioned at the installation points following drilling.

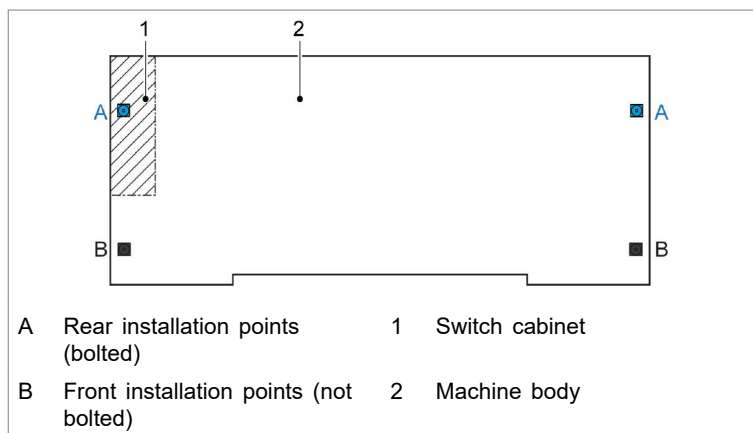

Fig. 70361

3. Drill the holes of the rear installation points through the machine.

Drill diameter in mm	16 mm
Drilling depth	85 mm

Tab. 2-18

- Clean the drilled holes.

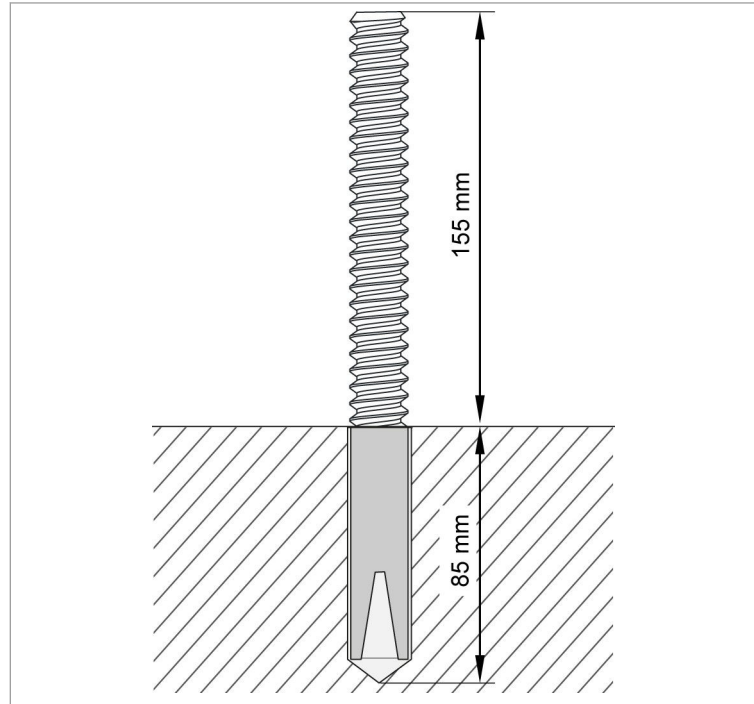

Fig. 68701

- Drive the drop-in anchors of the rear installation points into the holes.
 - The anchors must project out of the floor by about 155 mm.

8. Set-up and positioning

8.1 Preparing adjustable legs, positioning the machine

Preparing adjustable legs

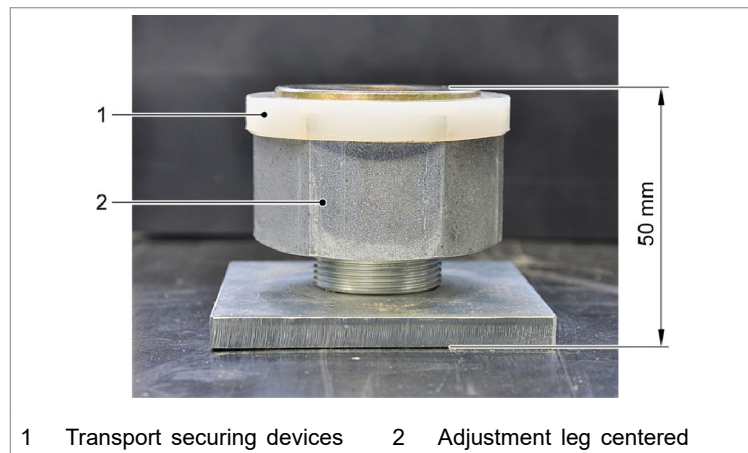

Fig. 69525

1. Adjust the adjustable legs of the machine so that a distance of 50 mm is achieved between the support surface and the bottom of the base plate.

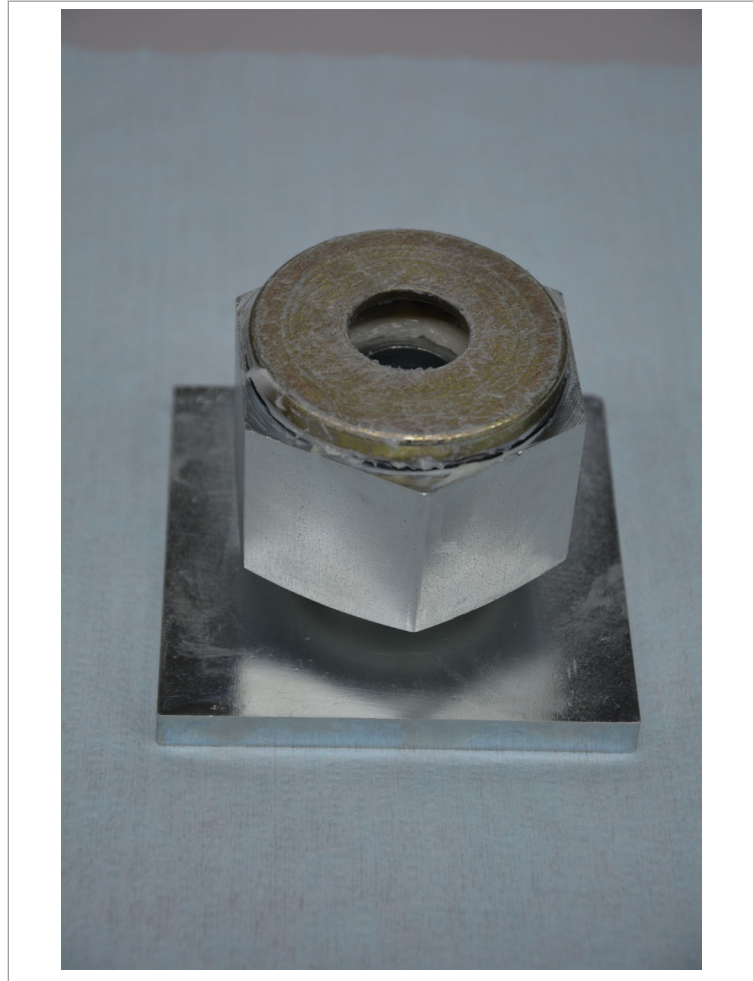

Fig. 72275

2. Remove the transport securing devices of the adjustable legs.

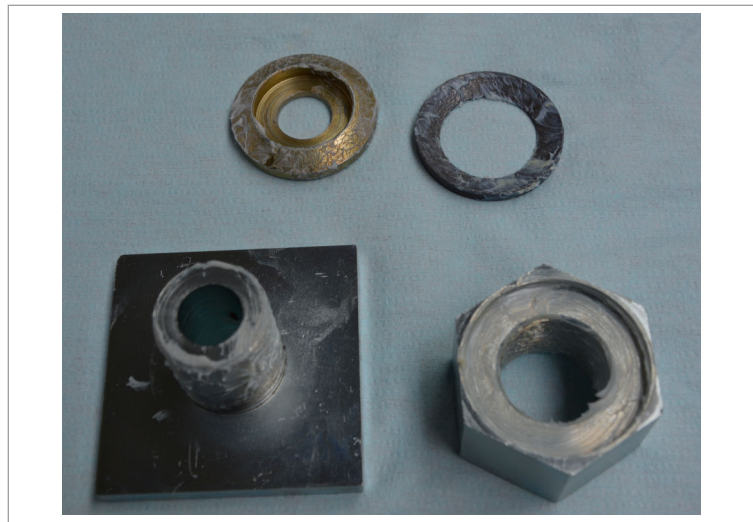

Fig. 72274

3. Lightly grease ball cups and spherical washer on both sides and the thread, if required.

Positioning the machine

⚠ CAUTION

Crush injuries due to machine falling down/tipping over!

- Supports must be placed beneath the machine when working with the machine in raised position.

⚠ DANGER

The machine is tilting forwards!

Risk of fatal injury!

- There must be no one in the danger zone during transport.
- The machine may only be transported with the transport securing devices mounted.
- The machine may be operated only if it is anchored firmly in the foundation.

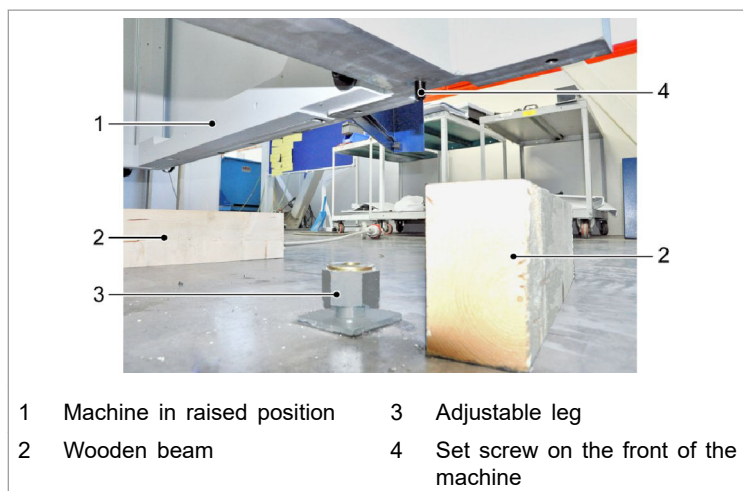

Fig. 69527

4. Using the indoor crane or hydraulic jack, raise the machine about 300 mm and place wooden beams beneath it to prevent it from falling/tipping over.

Note

The machine is not anchored to the factory floor at the front!
The set screws ensure that the adjustment legs do not slip out of place.

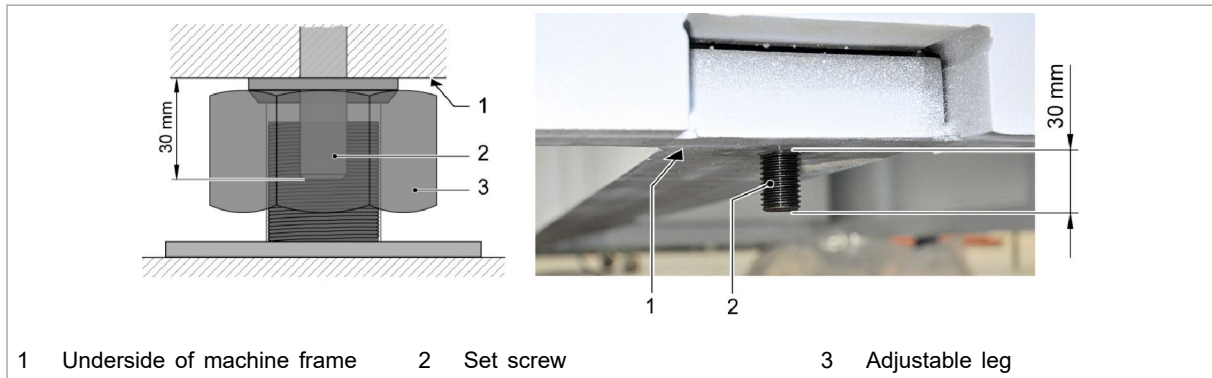

Fig. 69528

5. At the front of the machine, fully unscrew the set screws of the adjustable legs about 30mm out of the machine body and glue with Loctite.
 - ▶ Allen key, AF 8
6. At the front of the machine, position the adjustable legs under the set screws.
7. At the rear of the machine, guide the adjustable legs into the drop-in anchors and align them.
8. Remove the wooden beams and carefully lower the machine onto the adjustable legs.
9. Screw the nuts (2 x M16) and plain washer loosely onto the rear anchor.
 - ▶ Do not tighten because the machine must first be set up and aligned by a TRUMPF service engineer.
 - ▶ Tightening nuts on the rear anchors is performed by a TRUMPF service engineer.
10. Align the base plates of the adjustable legs parallel to the machine body.
 - ▶ Do not remove any transport devices!
 - ▶ Transport devices are painted orange and will be removed by the TRUMPF service engineer.

9. Support bracket

9.1 Assemble the support bracket

Note

Two support brackets are provided with the machine.

These only have to be fastened on the machine frame.

The support brackets are screwed directly to the machine frame.

Positioning across the entire table length is possible in 160 mm steps.

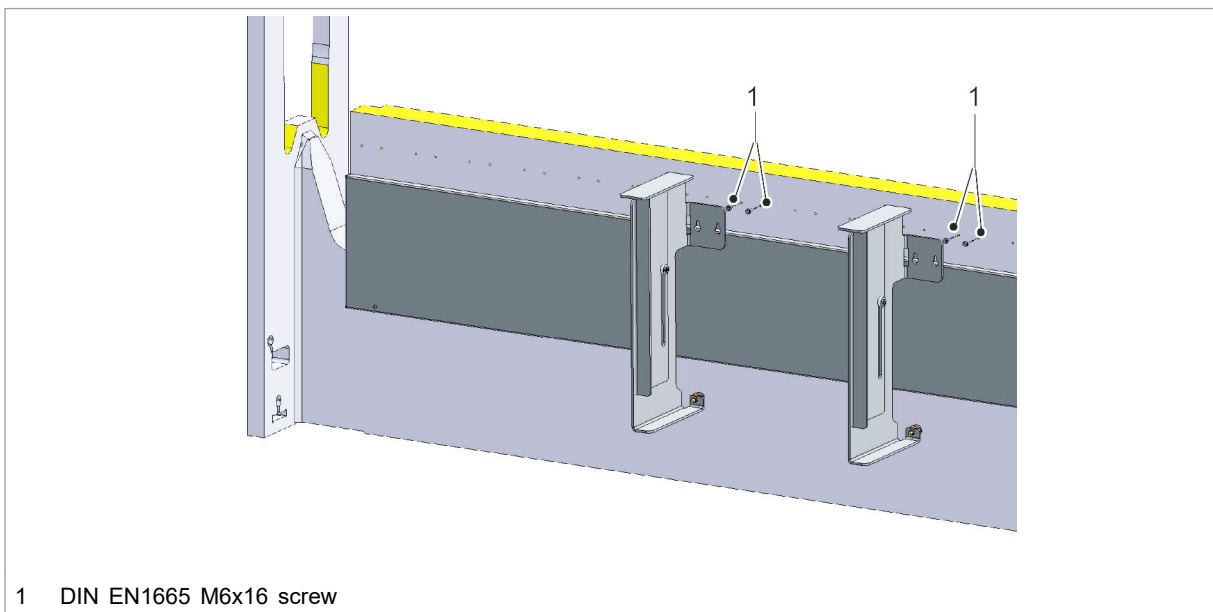

Fig. 102834

1. Screw the screws provided for fastening (DIN EN1665 M6x16) onto the desired position on the machine table.
2. Suspend the support brackets over the keyholes and screw on.

10. Foot switch and network cable

10.1 Connect the foot switch and network cable

- Preparations** 1. Open the electrical cabinet and service doors

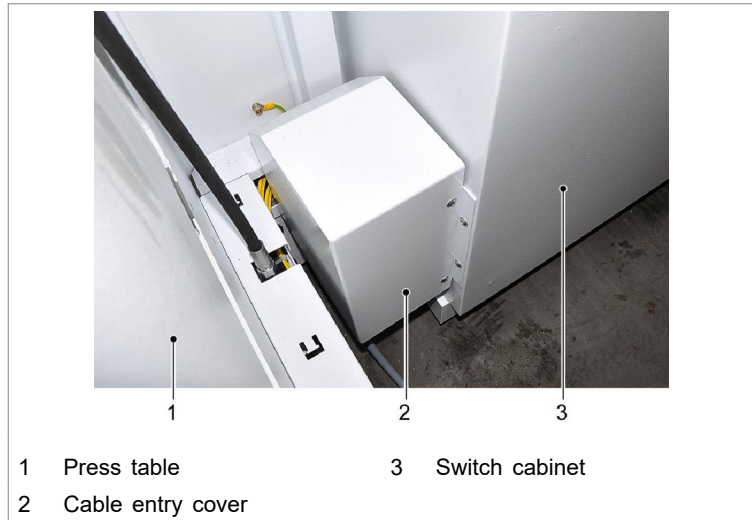

Fig. 69532

2. Remove the cover of the cable entry at the bottom of the electrical cabinet inside the machine (2xM6).

- Allen key AF 4

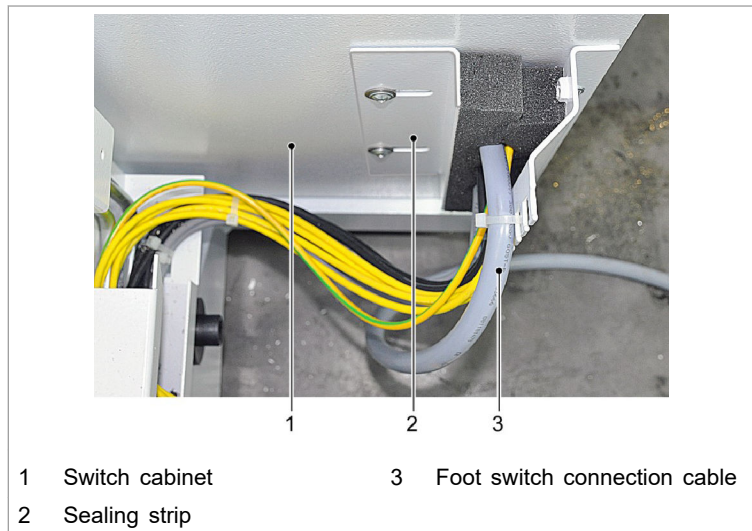

Fig. 69533

3. Loosen the left sealing strip of the cable entry (2xM6) and slide it towards the outside.

- Allen key AF 4

- Connecting the foot switch**
4. Route the connection cable of the foot switch into the electrical cabinet through the cable entry.

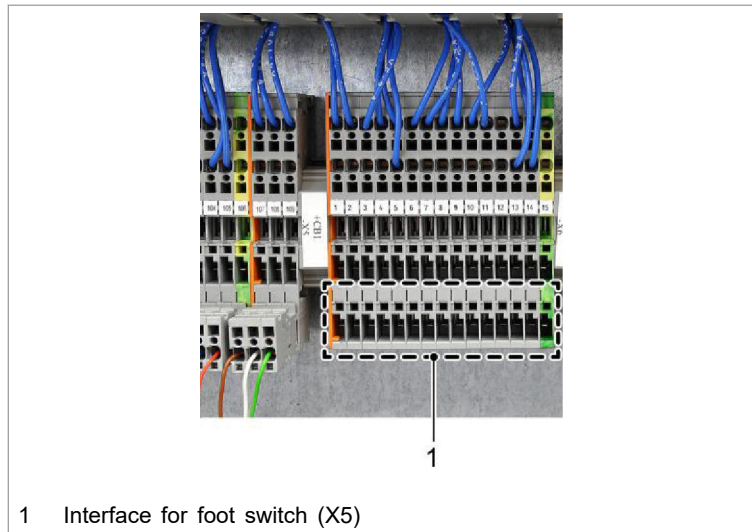

Fig. 70843

5. Plug the connection cable of the foot switch in at interface X5.

Connecting the network cable

6. Route the network cable into the electrical cabinet through the lower cable entry.

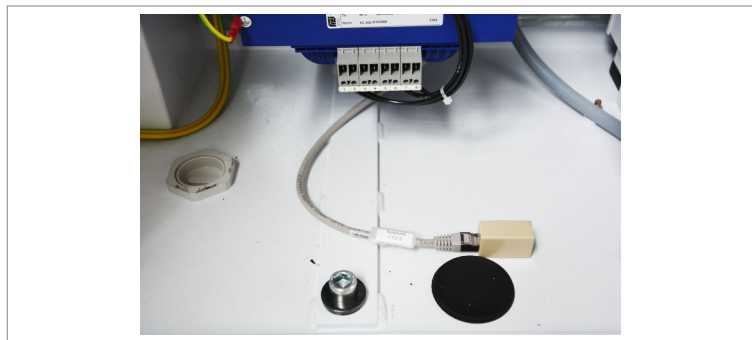

Fig. 84106

7. Connect the network cable to the RJ45 coupling.

Reworking

8. Route the network cable and connection cable tightly in the cable ducts of the electrical cabinet and pull the excess out through the cable entry.
9. Mount the sealing strip and cover in reverse order (see 2-75).

11. Electrical connection

11.1 Connecting the power cable

⚠ DANGER

Risk of fatal injury due to electric shock!

- The machine's electrical connection and work on the electrical cabinet may only be performed by qualified personnel (electricians)!
- The machine must be switched off when working on the electrical cabinet and secured against being switched back on.

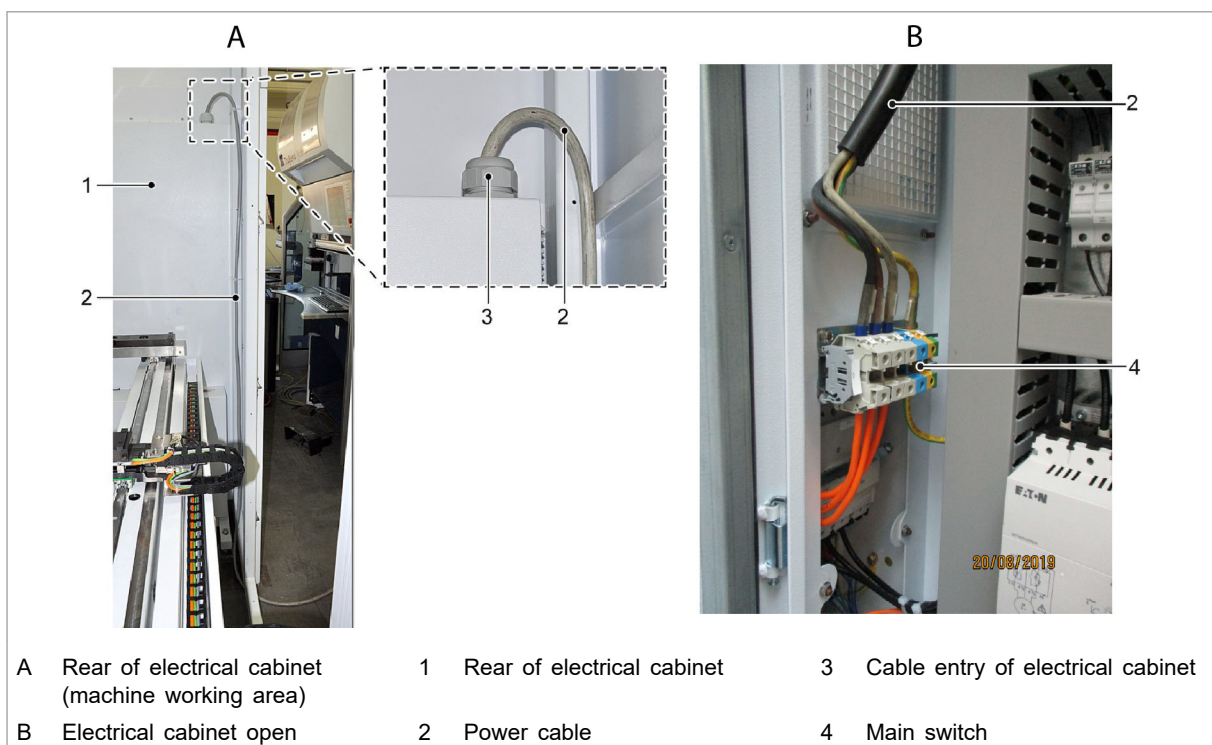

Fig. 102835

1. At the rear of the machine, pull the power cable into the machine's work area from below and route it up along the electrical cabinet to the cable entry.
2. Guide the power cable in at the upper cable entry of the electrical cabinet.
3. Open the cable ducts in the electrical cabinet.

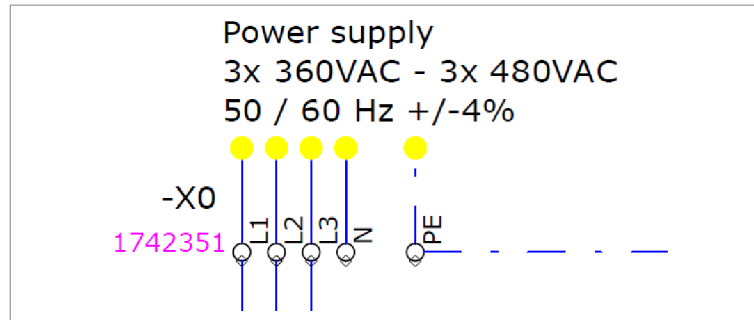

Fig. 102836

4. Have a qualified electrician connect the machine to the power supply.
5. Place the power cable in the cable ducts and route it tightly towards the outside.
6. Close the cable ducts in the electrical cabinet.
7. Using cable ties, stow the power cable safely in the machine work area.